

AM 09/I.14m - AM 15/I.14m

MATRICULATION AND SECONDARY EDUCATION CERTIFICATE EXAMINATIONS BOARD
UNIVERSITY OF MALTA, MSIDA

MATRICULATION EXAMINATION
ADVANCED LEVEL
MAY 2014

SUBJECT:	ENGINEERING DRAWING/GRAPHICAL COMMUNICATION
PAPER NUMBER:	I
DATE:	9 th May 2014
TIME:	9.00 a.m. to 12.00 noon

Directions to Candidates

Write your index number where indicated at the top of all drawing sheets.

Attempt **any five** questions.

Programmable calculators **cannot** be used.

Unless otherwise stated:

- a. drawings should conform to B.S. or equivalent (ISO) standards;
- b. all dimensions are in millimetres;
- c. all answers are to be accurately drawn with instruments;
- d. unless otherwise stated, all construction lines must be left in each solution;
- e. drawing aids may be used.

Dimensions not given should be estimated.

Careful layout and presentation are important.

Marks will be awarded for accuracy, clarity and appropriateness of constructions.

Question 1

The cylindrical cam shown has its end machined to the required shape to form an end cam.

- a) Draw the incomplete elevation and plan of the end cam shown in Figure 1.
- b) Construct the development of the cam surface, if the end cam is to move the roller-ended follower as follows:

Follower dwells for one twelfth of a revolution of the cam.
Follower to move 120mm upwards for the next half revolution with uniform acceleration and uniform retardation motion.
Follower to dwell for one-twelfth of a revolution.
Follower to return to the start position with simple harmonic motion the remainder of the revolution of the cam.

- c) Complete the front elevation of the cam by drawing a fair curve showing the profile of the end cam, including the hidden detail.

Note: The cam rotation is anticlockwise.

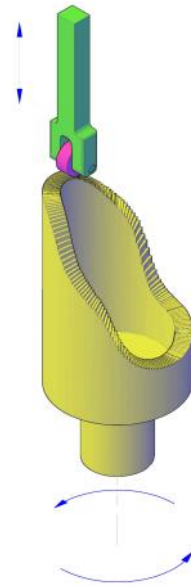

(20 marks)

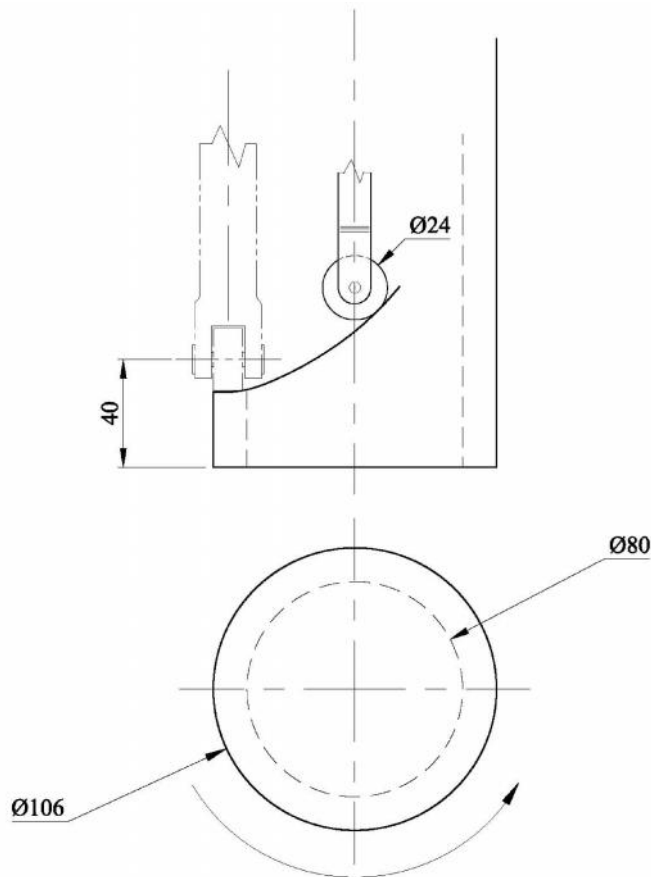

Figure 1

Question 2

The illustration shows a stand used for exhibiting tools and various engineering items on display for sale in an establishment. The display stand is formed from two continuous strips of mild steel (flat) bars welded to a base. The flat bars are twisted to form a double right-hand helix.

Using the dimensions of the stand, shown in Figure 2, draw, to a scale of 1:1, a front elevation showing a true projection of one and a half pitches of the helix.

All helices are to be shown.

Hidden detail is not required.

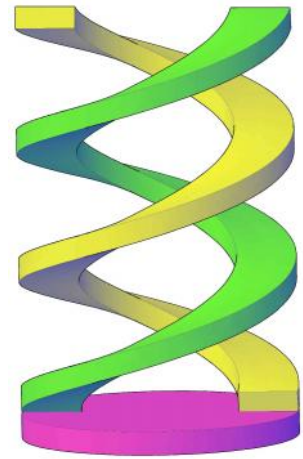

(20 marks)

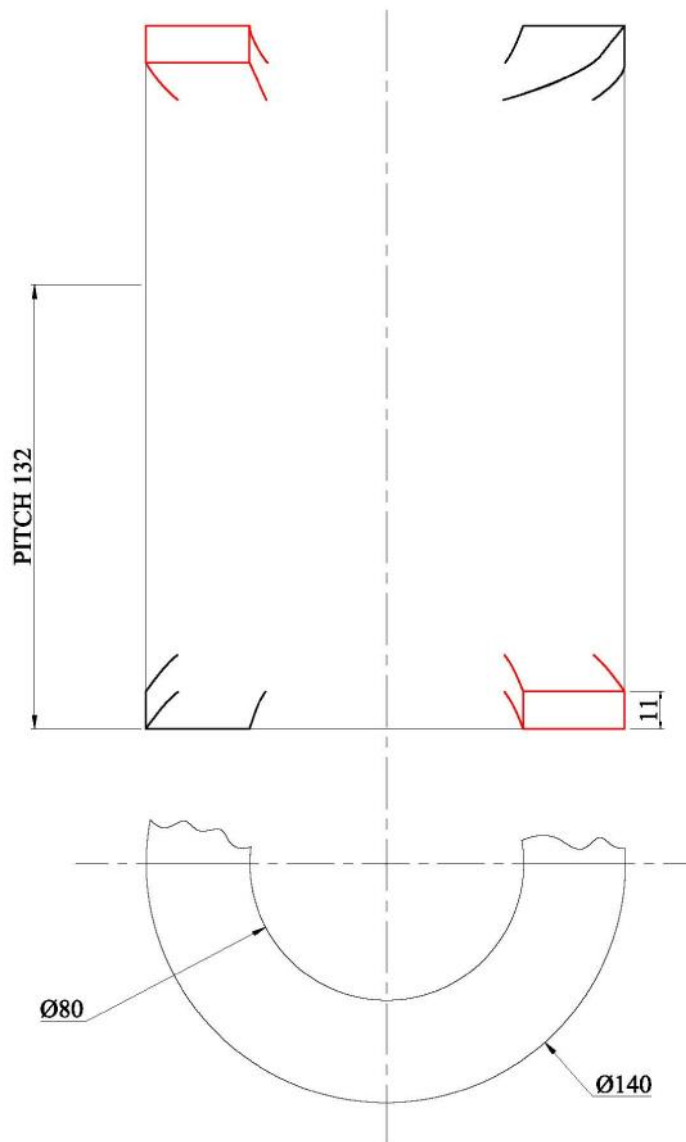
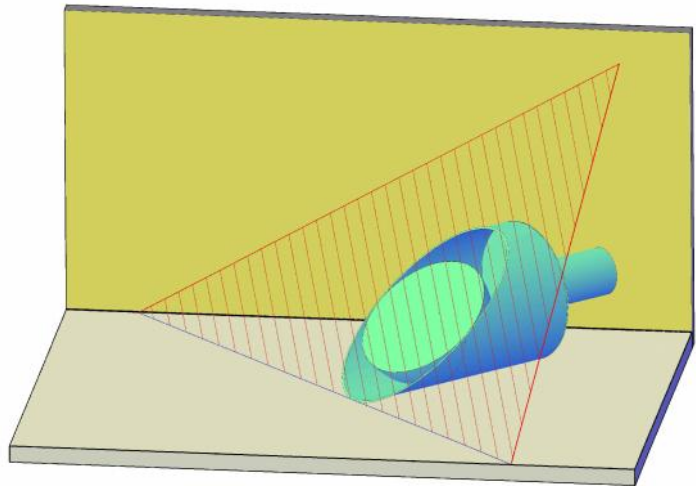

Figure 2

Question 3

Figure 3 below shows the plan and elevation of a sphere inside a cylindrical scoop. The lines VT and HT represent the traces of an oblique plane which cuts both the cylinder and the sphere. The cylindrical scoop rests on the horizontal plane at an angle of 45° to the vertical plane.



Draw full size:

- a) The auxiliary view showing the oblique plane as an inclined plane. Measure and state the true angle the oblique plane makes with the horizontal plane.
- b) The given elevation and plan with the portion in front of the cutting plane removed.

Notes:

Do not show the section hatching.

The material of the cylinder is of negligible thickness.

(20 marks)

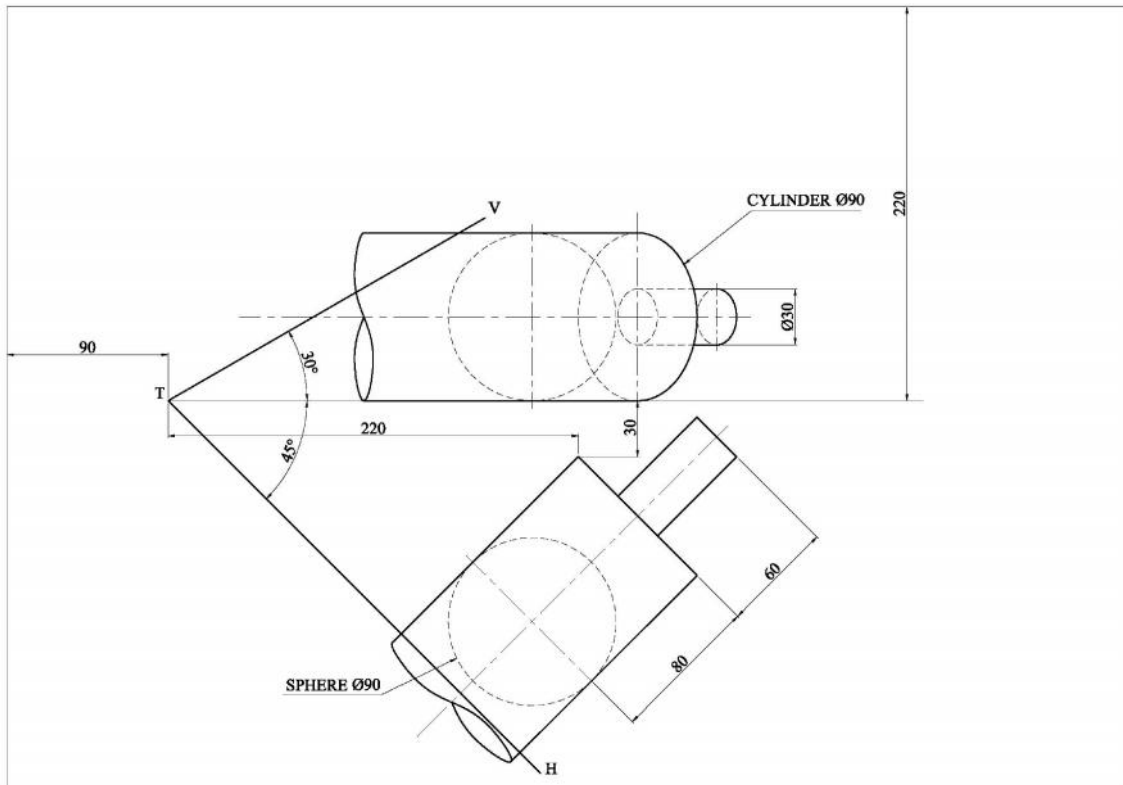

Figure 3

Question 4

Part of a mechanism installed on a machine moves two racks in opposite direction by means of a gear wheel. Figure 4 shows the racks in mesh with the driving gear wheel.

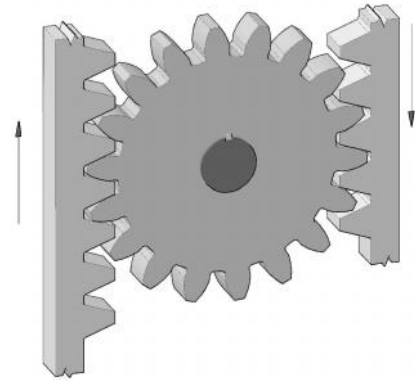

Figure 4

- a. Using the formulae and the following data, complete the table in Figure 4a before beginning the drawing.
 Driving pinion – 18 teeth.
 Module – 16
 Pressure angle 20°
 The pinion teeth profile is of true involute form.
- b. Construct, full size, a pinion tooth flank face of true involute form.
- c. Draw one tooth of the pinion meshing with two teeth of a straight rack.
 Note:
 The racks are to be presented in a vertical position with the pitch point of the gear tooth on the same horizontal centre-line;
 (i) on the left hand side.
 (ii) on the right hand side (as shown in Figure 4a).

(20 marks)

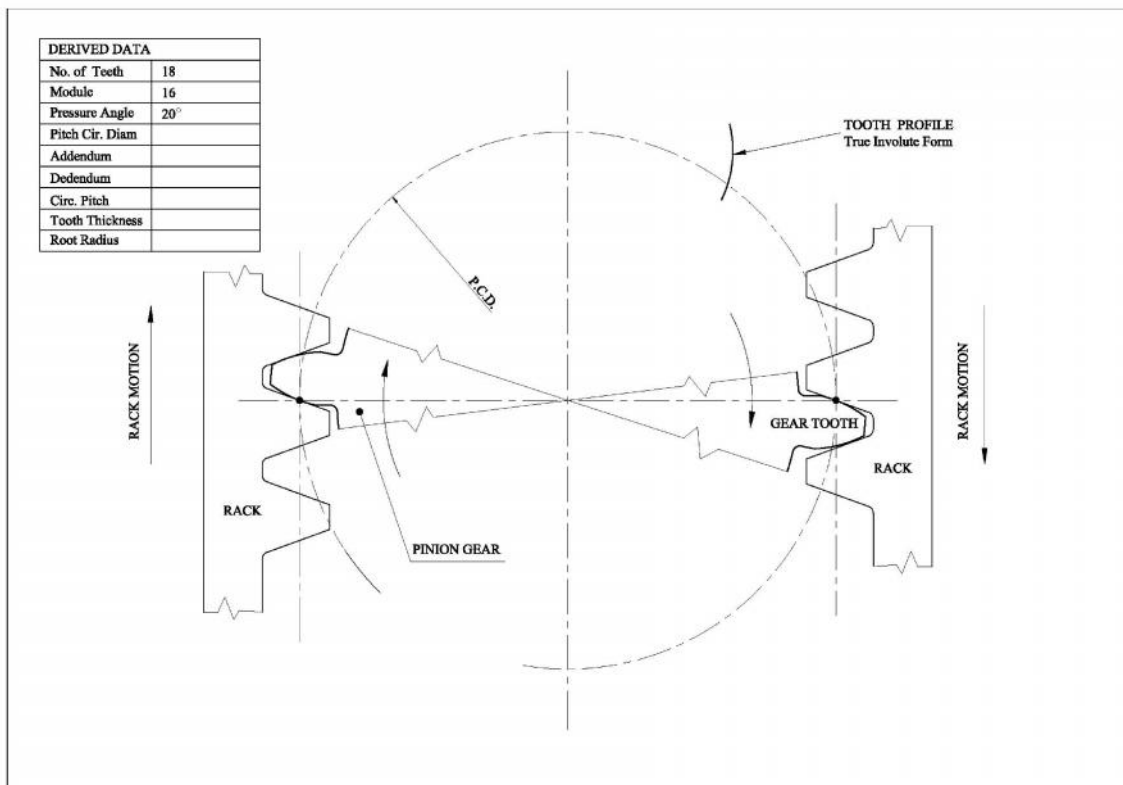
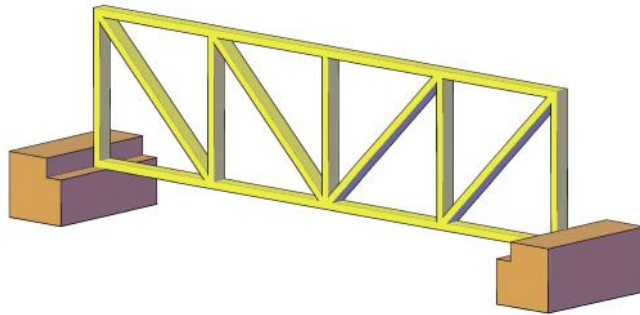

Figure 4a

Question 5

The roof truss structure, shown on the right, is supported at ends R_L and R_R .

- Using a scale of 10mm representing 1m, draw the space diagram shown in Figure 5.
- Construct the force diagram by using a polar diagram and a link polygon. Use a scale of 10mm representing 10kN and present a clear notation system.



- Determine graphically and state the magnitude and direction of the reaction at R_L and R_R .
- State the magnitude and sense of the forces of the left hand half of the members distinguishing between struts and ties.

(20 marks)

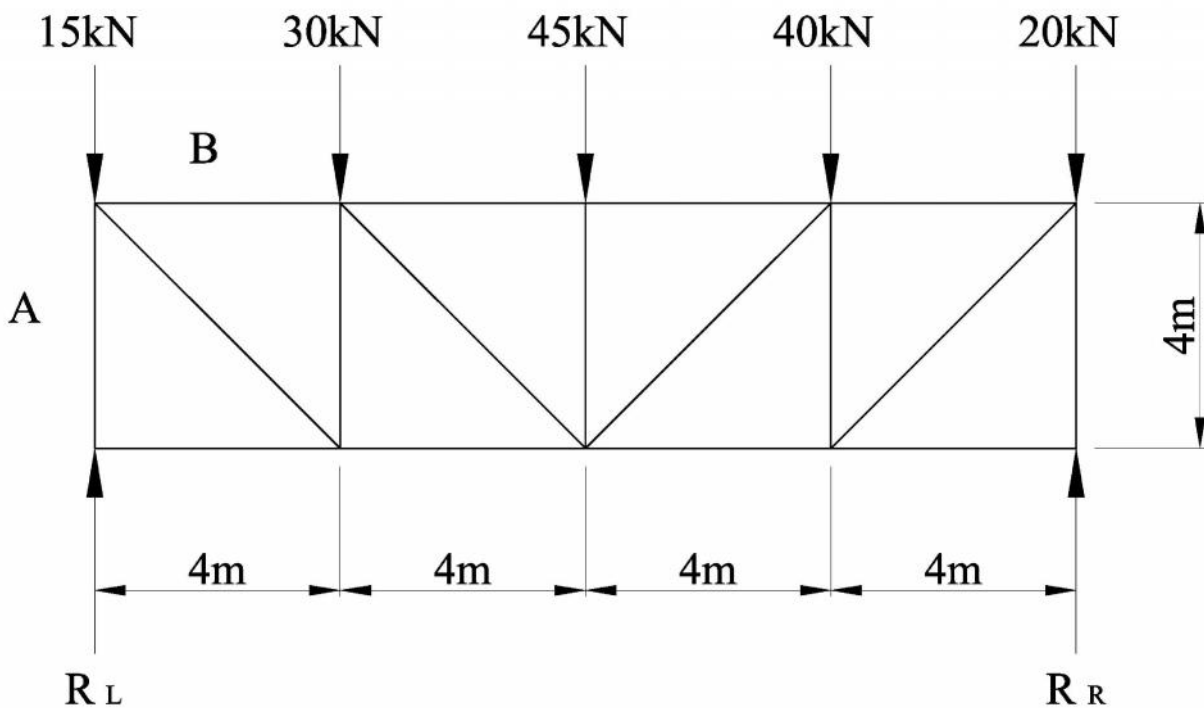

SPACE DIAGRAM

Figure 5

Question 6

An illustration of a right cone interpenetrated by a compound semi-cylinder and semi-square prism is shown. Incomplete orthographic views of the interpenetrating geometric solids are given in Figure 6.

- a) Draw full size, the given incomplete views together with a view in the direction of arrow A. Include all the curves of intersection and show all hidden details.
- b) Construct the surface development of half of the right cone, showing the opening of the semi-square prism and the semi-cylinder.

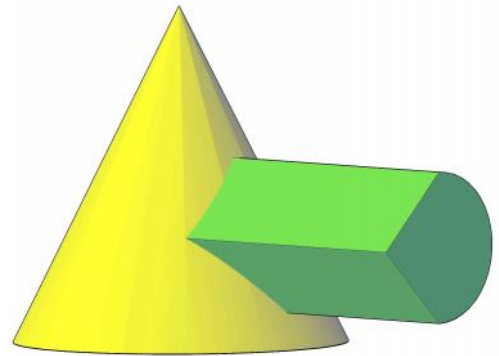

(20 marks)

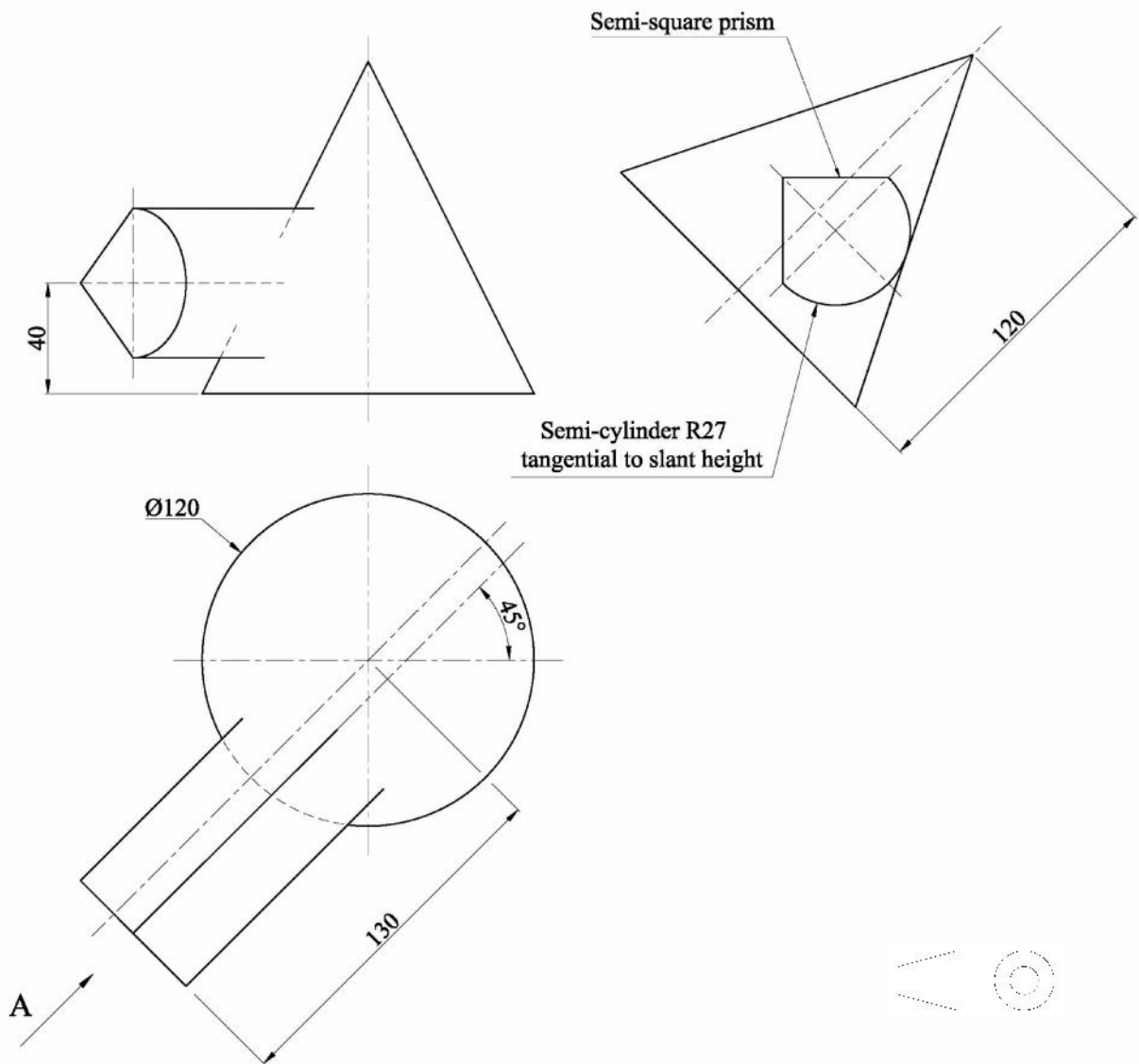

Figure 6

MATRICULATION AND SECONDARY EDUCATION CERTIFICATE EXAMINATIONS BOARD
UNIVERSITY OF MALTA, MSIDA

MATRICULATION EXAMINATION
ADVANCED LEVEL
MAY 2014

SUBJECT:	ENGINEERING DRAWING
PAPER NUMBER:	II
DATE:	10 th May 2014
TIME:	9.00 a.m. to 12.00 noon

Directions to Candidates

Write your index number where indicated at the top of all drawing sheets.

Attempt **question 1** and any other **two** questions.

Programmable calculators **cannot** be used.

Unless otherwise stated:

- a. drawings should conform to B.S. or equivalent (ISO) standards;
- b. all dimensions are in millimetres;
- c. all answers are to be accurately drawn with instruments;
- d. all construction lines must be left on each solution;
- e. drawing aids may be used.

Dimensions not given should be estimated.

Careful layout and presentation are important.

Marks will be awarded for accuracy, clarity and appropriateness of constructions.

Mark allocations are shown in brackets.

Question 1 carries 60 marks. Questions 2, 3 and 4 carry 20 marks each.

Question 1

The diagram on the attached sheets shows details of an adjustable stand, which is used to form a Dial Indicator. The attached sheets shows the details of the components which are assembled as follows;

The datum platform (item 1) is pressed into the spot faced 20mm diameter hole of the base casting (item 2). The support column (item 4) is pressed into the 22mm hole of the base casting. The coarse adjustment ring (item 3) is screwed onto the M30 square threaded portion of the support column at a distance of 70mm measured from the ring top face to the datum platform surface. The bracket (item 5) is fitted over the support column resting on the adjustment ring. A clamp screw (item 6) locks the bracket in a rigid position onto the support column, with the M10 threaded end screwed into the M10 tapped hole of the bracket. The end of travel cap (item 7) is (mounted) placed on the top end face of the support column and is retained (secured in position) by means of the cheese head screw (item 8). The support arm (item 9) is placed with the flat Face A, 16mm wide flat surface, resting against the flat Face B of the bracket. The fine adjusting ring (item 10) is inserted into the 10mm slot of the support arm. The fine adjusting screw (item 11) is inserted through the 10mm diameter top hole of the bracket, passing through the 10mm diameter hole of the support arm, screwed into the adjusting ring, right through the lower 10mm diameter hole of the support arm. Rotation of the fine adjusting screw adjusts the gap between the datum platform and the datum centre, represented by the centre of M8 on the support arm. The M10 locking ring (item 12) is screwed to the adjusting screw and seats against the lower end (base) of the support arm. The support arm is located in position by means of the M6 threaded end of the fine adjusting screw into the M6 tapped hole of the bracket. The fine adjusting screw is tightened in place from its hexagonal head, aligning the arm-assembly in position.

Draw, full size, in first angle orthographic projection, the following views of the assembled components:

- a. sectional front elevation, the section plane is to be vertical and is to pass through the line of symmetry of the base, bracket and support arm;
- b. a complete side elevation in projection with (a) as seen from the left.

Dotted lines representing hidden parts are not required. Cross-section views should be cross-hatched in the conventional manner.

- i) The centre of the M8 threaded hole of the support arm, (datum centre) is to be drawn 120mm above the datum platform.
- ii) Present the cheese-head screw installation as a local section detail.

(60 marks total)

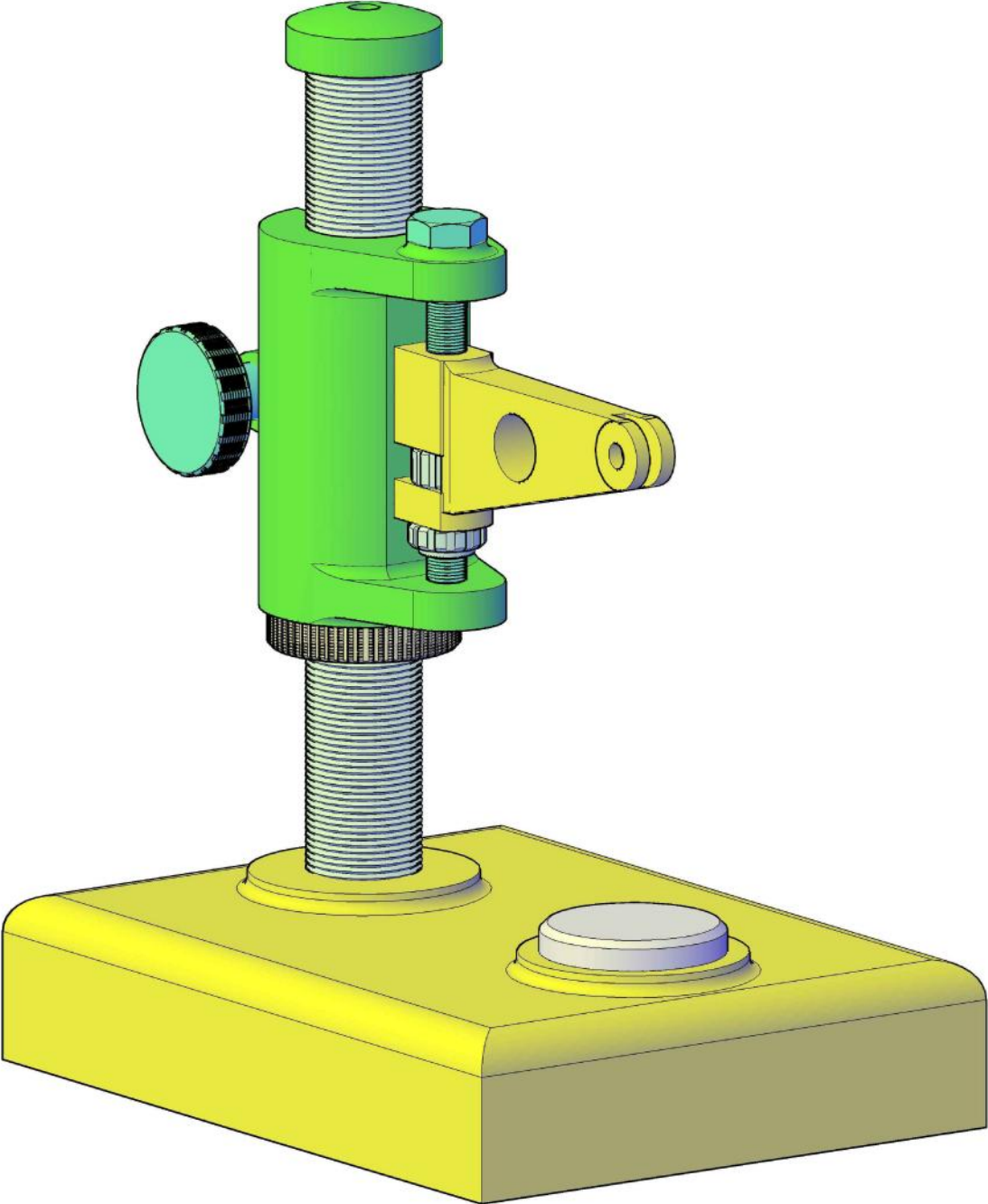

Figure 1b

Question 2

A clutch is a mechanical device that provides transmission of power from one driving member to another driven member when engaged. Clutch disengagement allows to disconnect the driven member from the drive.

Figure 2 below depicts an incomplete dimensioned elevation of a cone clutch.

Draw, a half sectional elevation of the cone clutch.

- i) The clutch is to be shown in the engaged position.
- ii) Include in your drawing a simple illustration how disengagement and re-engagement of the drive is achieved.
- iii) The cone clutch has conical friction surfaces. Name the material used for the facing.
- iv) Show how the two rotating shafts are connected to the clutch.
- v) State the taper angle.

(20 marks total)

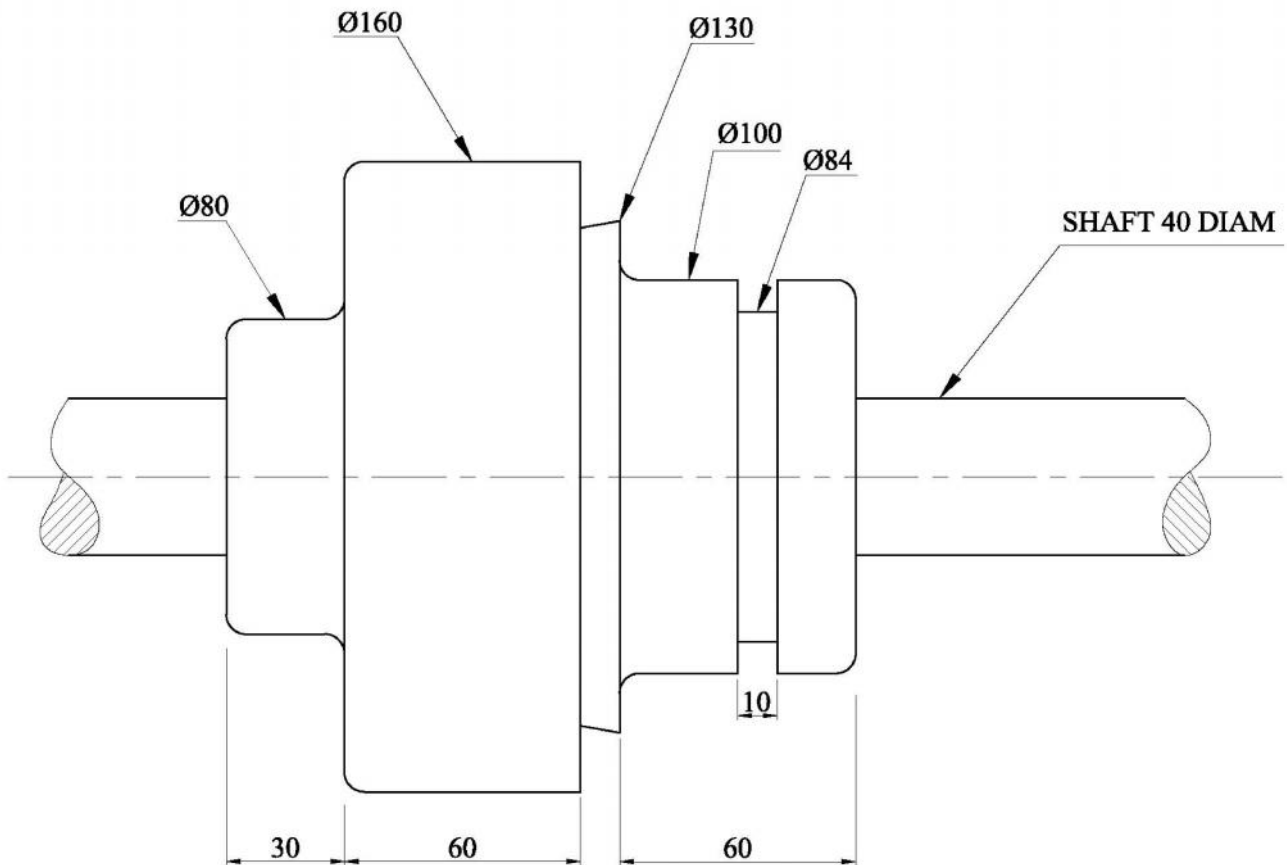

Figure 2

Question 3

A standard method of indicating weld symbols on engineering drawings gives information as to the type, size and position of welds.

a. **The system makes use of the following;**

1. a weld symbol,
2. a reference line,
3. an arrow,
4. a dimension.

Draw a figure showing how these four basic parts are represented.

b. For each of the following, draw figures giving specific details of welding symbols on the most convenient view.

- i) Location of weld symbol on reference line.
- ii) Fillet weld
- iii) Double bevel butt weld
- iv) When a continuous weld is required all round a component.

You may adopt the method shown in Figure 3 below for your answer.

c. Draw a general symbol which may be applied when the welds are to be performed "on site" during construction.

(20 marks total)

FORM OF WELD	ILLUSTRATION AND SYMBOL
<p>SINGLE -V BUTT WELD</p>	

Figure 3

Question 4

The two components shown in Figure 3 are to be connected together by a special bolt having the following design specification;

Design specification of the bolt:

- must not turn in detail 2,
- must have a hexagonal head,
- must be secured by a lock nut device and washer,
- must have a clearance in the bush of Detail 1, and the holes B and C in Detail 2. A, B and C have a bore tolerance of H 8. Use the table 3(a) below to select the fit design according to the standard,
- must have provision for fitting of a grease nipple which will allow supply grease to the bush.

Design and draw, to a suitable scale, the special bolt.

The drawing must be dimensioned so that the component can be manufactured. The drawing must include the dimensions of the bolt shank diameter with upper and lower limits.

Complete the table 3(b) shown.

(20 marks)

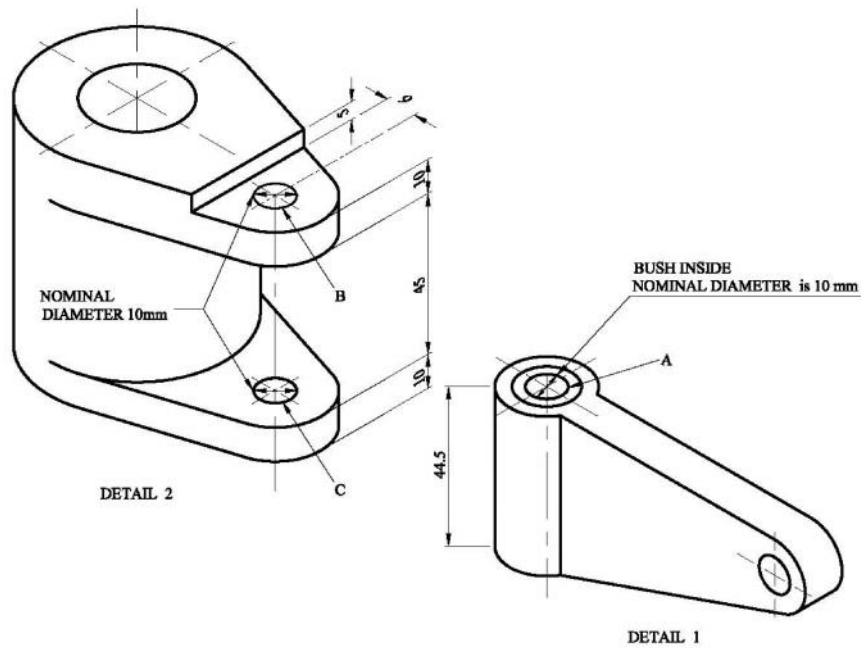

FIGURE 3

LIMITS OF TOLERANCE					
NOMINAL SIZE		H 8		f 7	
Over	Up to	Upper	Lower	Upper	Lower
3	6	+ 18	0	- 10	- 22
6	10	+ 22	0	- 13	- 28
10	18	+ 27	0	- 16	- 34

TABLE 3 a

'A' BUSH INSIDE DIAMETER	mm
Size Upper Limit	
Size Lower Limit	

BOLT SHANK DIAMETER	mm
Size Upper Limit	
Size Lower Limit	

TABLE 3 b

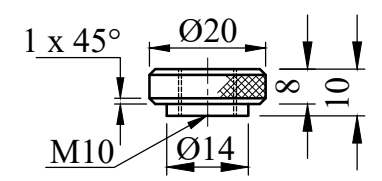
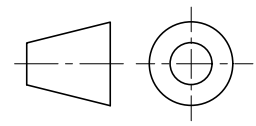

LOCKING RING (12)

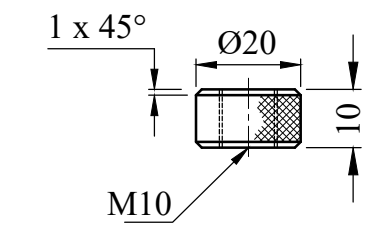

FINE ADJUSTING RING (10)

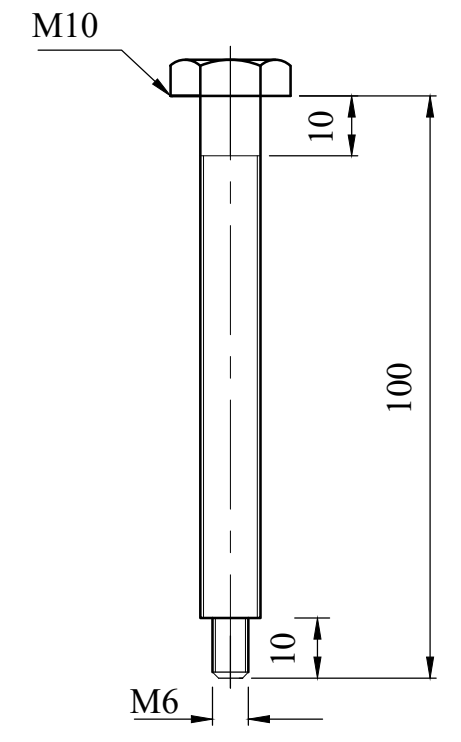

FINE ADJUSTING SCREW (11)

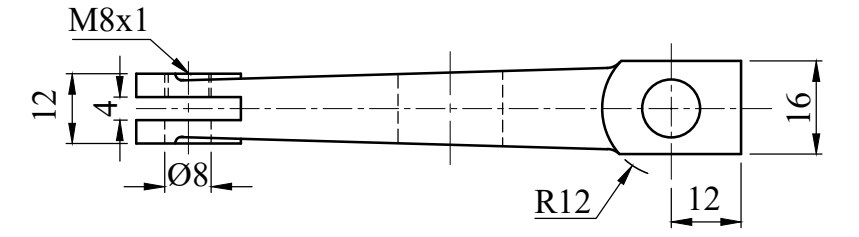
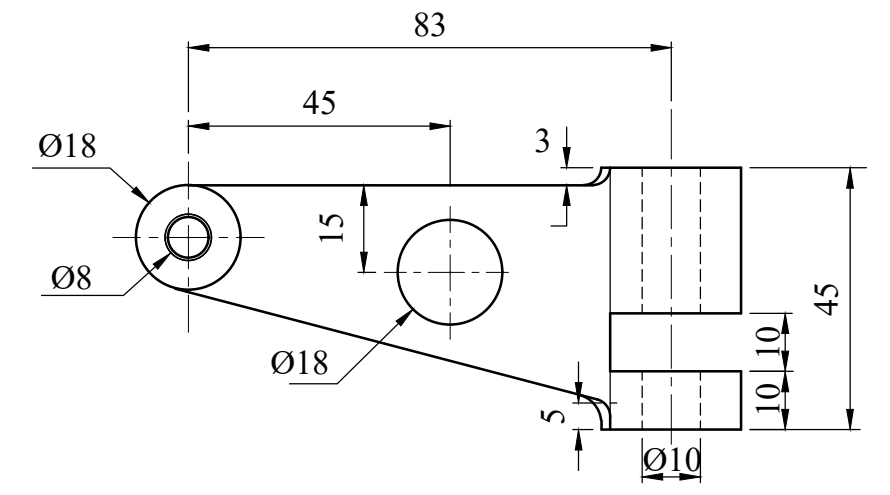

SUPPORT ARM (9)

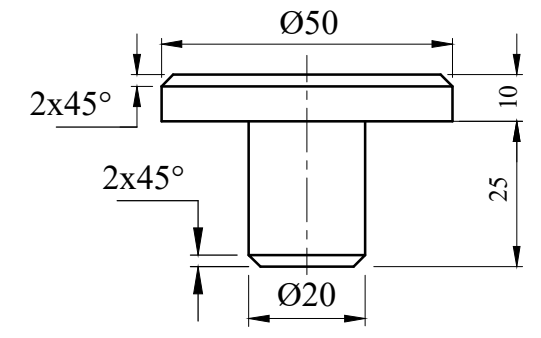

DATUM PLATFORM (1)

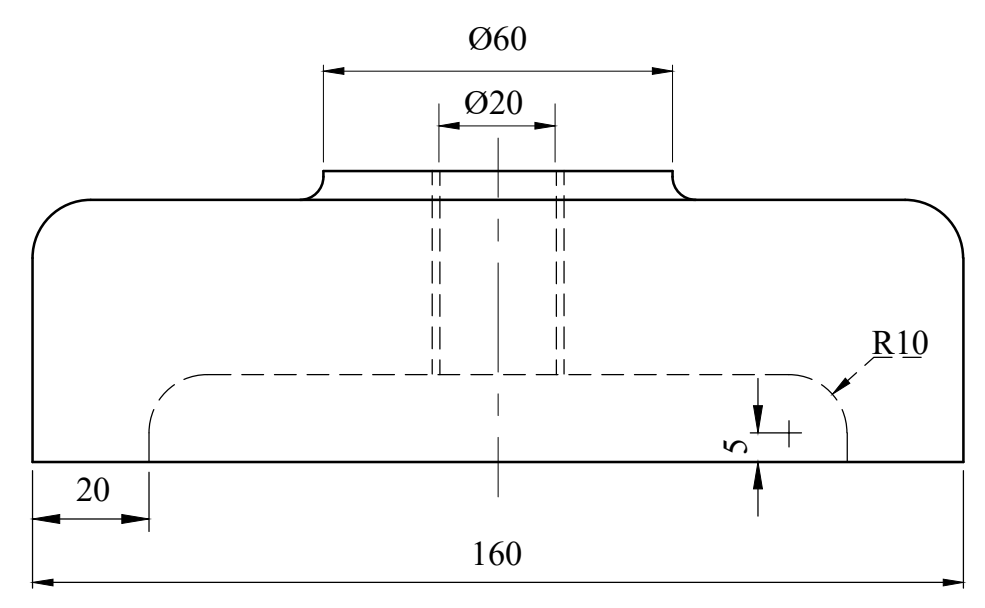
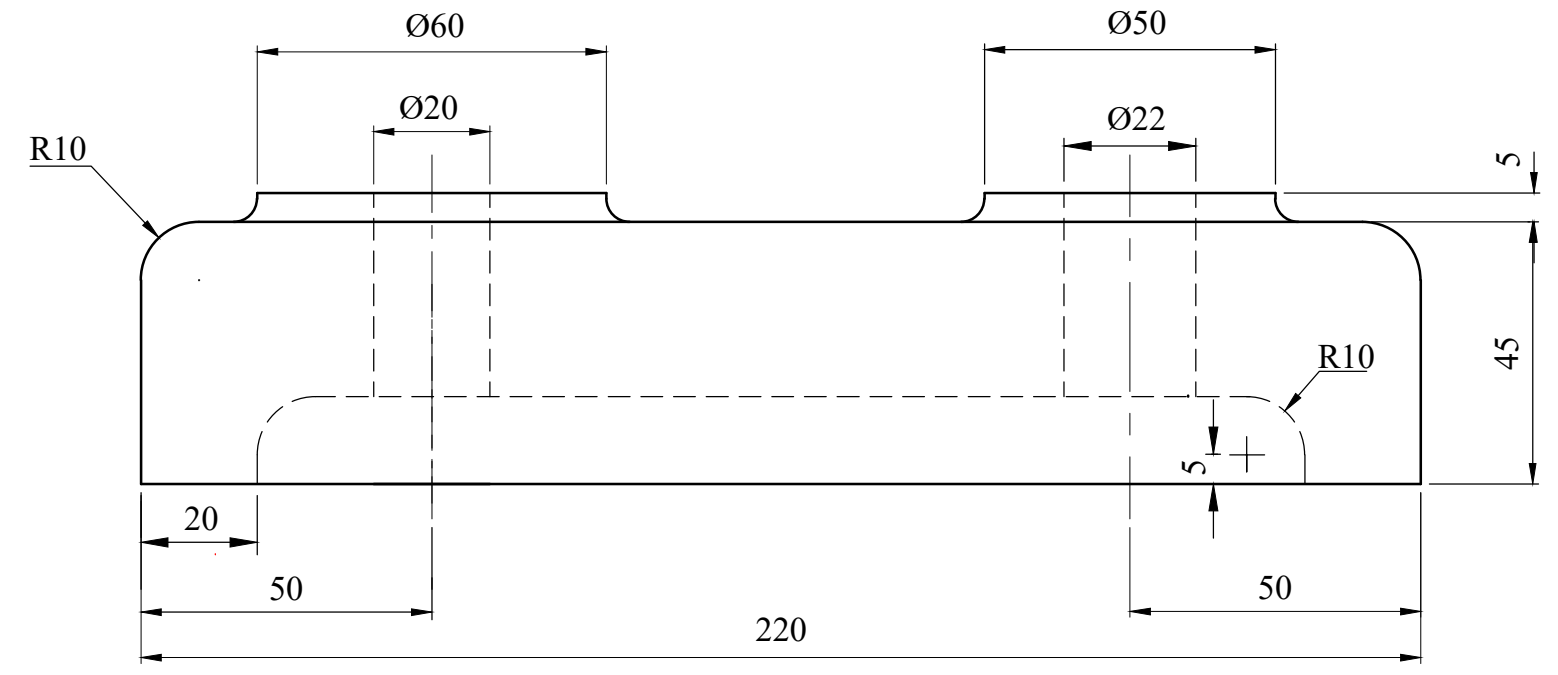

BASE CASTING (2)