

MATRICULATION AND SECONDARY EDUCATION CERTIFICATE EXAMINATIONS BOARD
UNIVERSITY OF MALTA, MSIDA

MATRICULATION EXAMINATION
ADVANCED LEVEL
SEPTEMBER 2016

SUBJECT:	ENGINEERING DRAWING/GRAPHICAL COMMUNICATION
PAPER NUMBER:	I
DATE:	2 nd September 2016
TIME:	9.00 p.m. to 12.05 p.m.

Directions to Candidates

Write your index number where indicated at the top of all drawing sheets.

Attempt **any five** questions.

Programmable calculators **cannot** be used.

Unless otherwise stated:

- a. drawings should conform to B.S. or equivalent (ISO) standards;
- b. all dimensions are in millimetres;
- c. all answers are to be accurately drawn with instruments;
- d. unless otherwise stated, all construction lines must be left in each solution;
- e. drawing aids may be used.

Dimensions not given should be estimated.

Careful layout and presentation are important.

Marks will be awarded for accuracy, clarity and appropriateness of constructions.

Question 1

A pin-jointed frame structure is shown in Figure 1. Using a scale of 8 mm representing 1 m, and a force scale of 5 mm representing 1 kN:

- (a) Construct:
 - (i) the space diagram; (3 marks)
 - (ii) a polar diagram, a link polygon and a force diagram. (6 marks)
(A clear notation system must be used.) (6 marks)
- (b) Show clearly, on the space diagram, the magnitude of the left and right reaction. (4 marks)
- (c) State whether the following members are in tension or in compression, including the magnitude of: (7 marks)
AG, GF, GH, EN, FN, MN and LM.

(20 marks total)

SPACE DIAGRAM

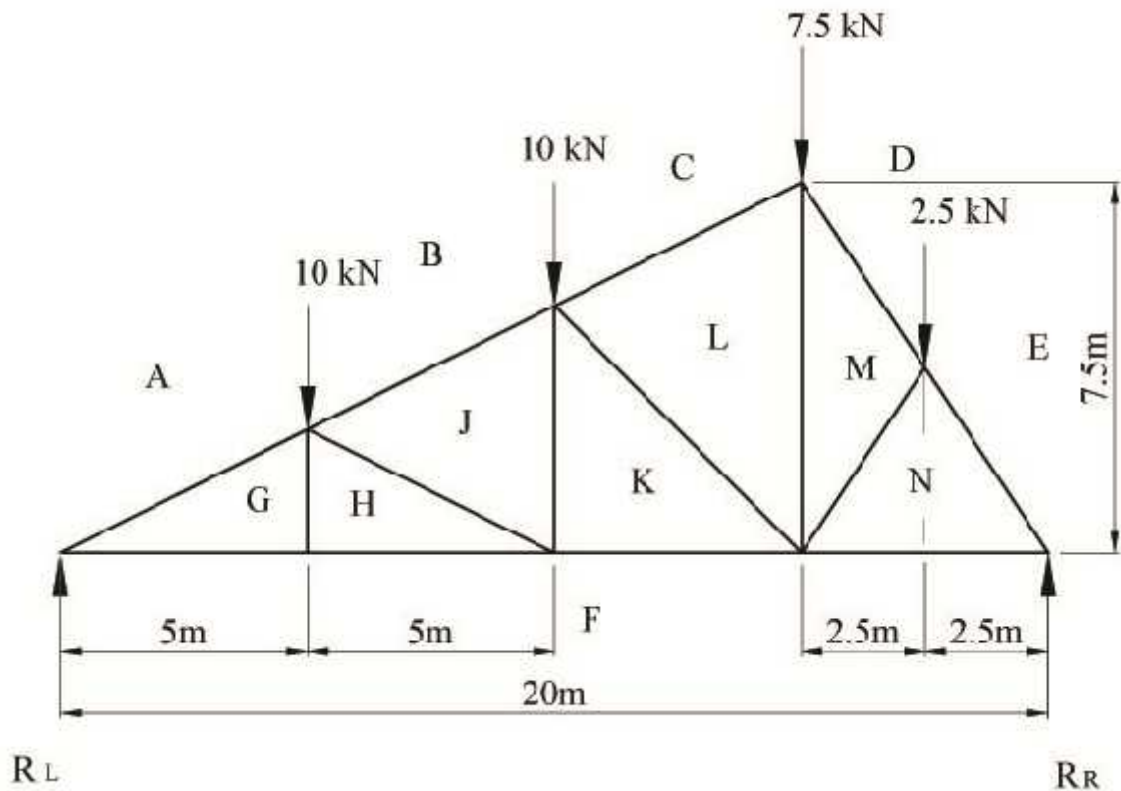

Figure 1

Question 2

A circular disc centre O, slides horizontally a distance of 180 mm to O_1 and then returns to its original position. During the first shift to O_1 , the disk rotates and completes one revolution about its own centre. During the return shift from O_1 to its original position, the disk does not revolve and the crank OA remains in the upright position. All motions of the disk are uniform. The lever AB slides freely through a guide at pivot block (point C). Crank OA is rigidly attached to the disc. Plot, full size, the locus of lever end B.

(20 marks total)

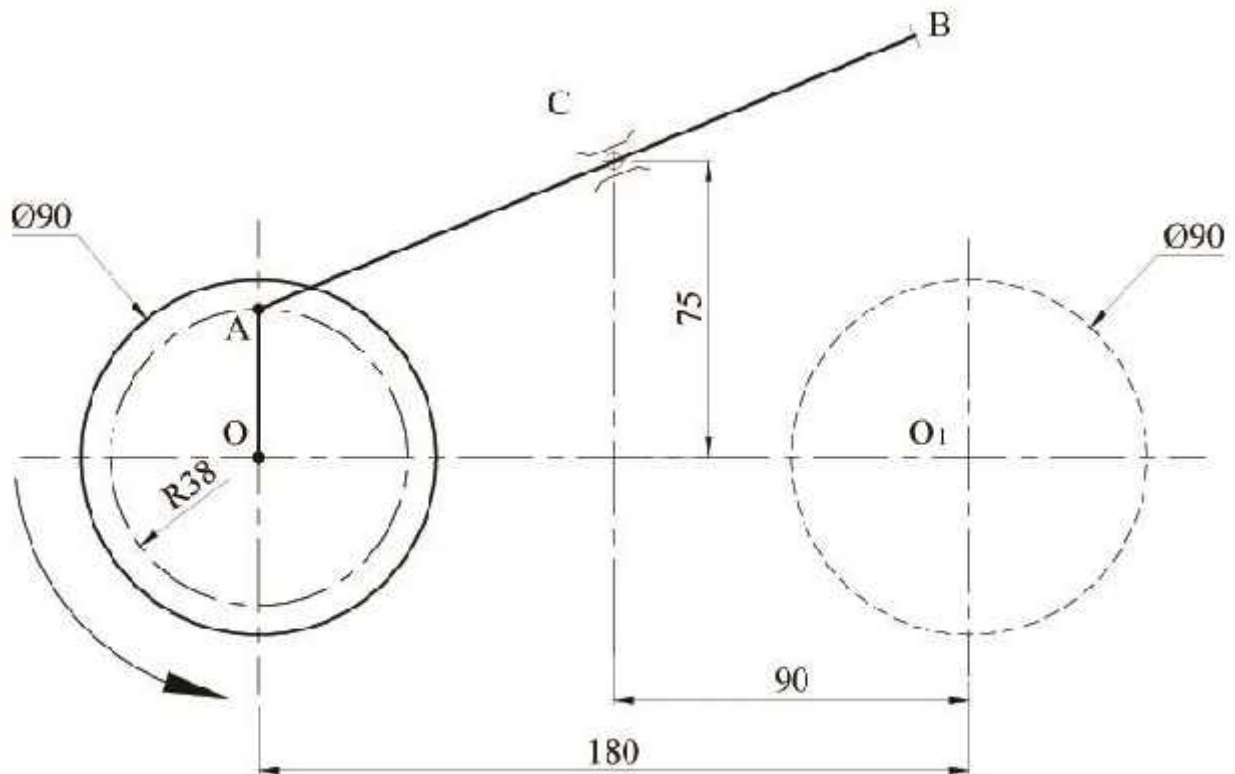

Figure 2

Question 3

An illustration of three spheres and a cylinder is shown in Figure 3a.

Sphere 'P', 100 mm diameter is in mutual contact with two smaller spheres 'Q' and 'R', both 60 mm diameter. All the spheres are resting on the horizontal plane. The axes of spheres 'P' and 'Q' are parallel to the vertical plane. Sphere 'R' is to be placed on the horizontal plane in contact with sphere 'P' and sphere 'Q', as shown in Figure 3b.

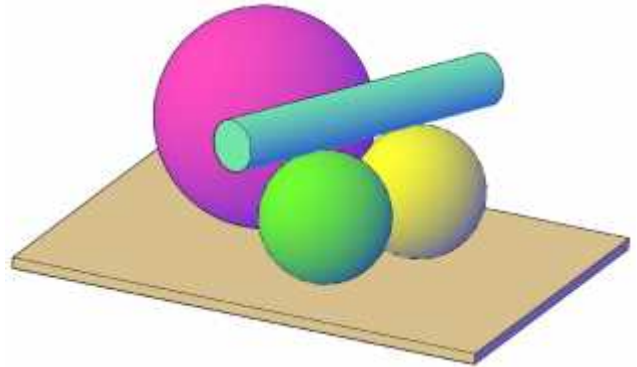

Figure 3a

Draw, full size, showing all construction lines:

- a. An elevation and plan of the spheres 'P' and 'Q'; (5 marks)
- b. Sphere 'R' in mutual contact with the other two spheres. (5 marks)

A right cylinder 24 mm diameter and 160 mm long, is to be placed resting on the two spheres 'Q' and 'R' in a horizontal position and in mutual contact with sphere 'P'.

- c. Draw an elevation and plan of the arrangement. (10 marks)

(20 marks total)

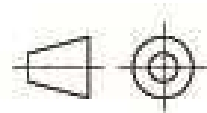
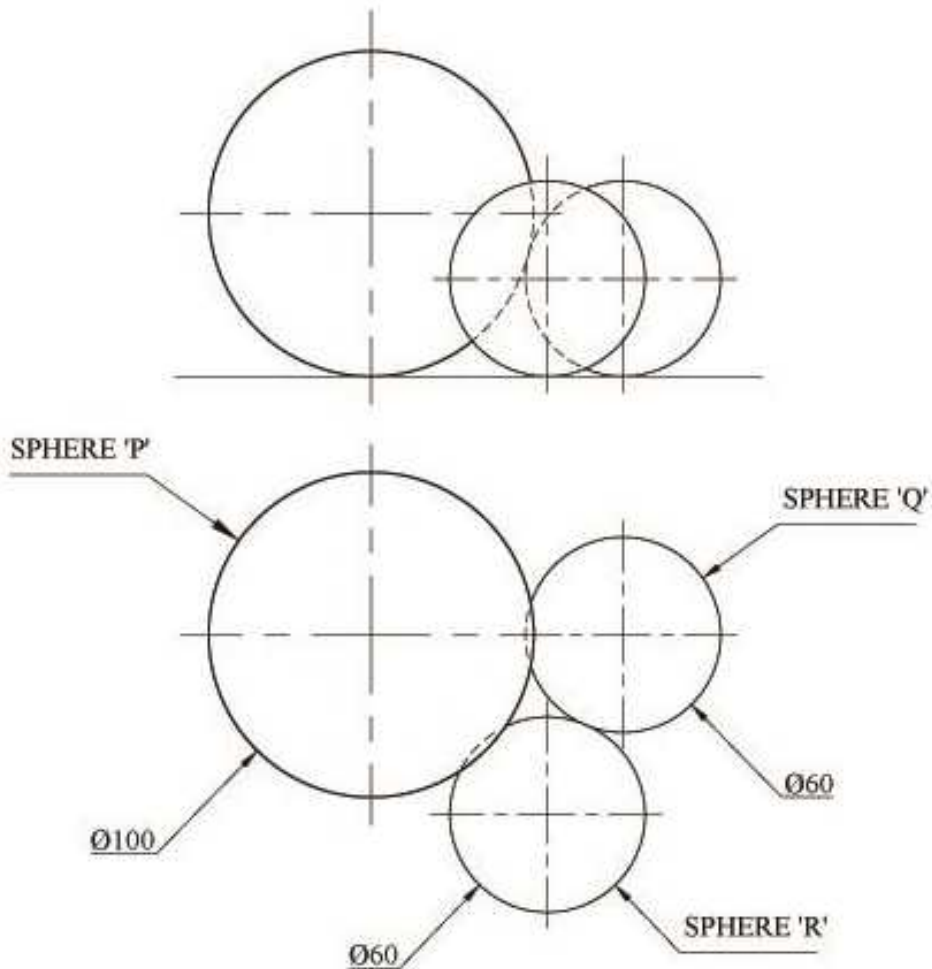

Figure 3b

Question 4

An **oblique** conical fitting is slotted to the profile as illustrated in Figure 4a.

- a) Reproduce, full size, the given incomplete two views and the auxiliary elevation, shown in Figure 4b. **(5 marks)**
 - b) Complete the two views, showing the curves of intersection. **(15 marks)**
- Show hidden detail. **(15 marks)**

(20 marks total)

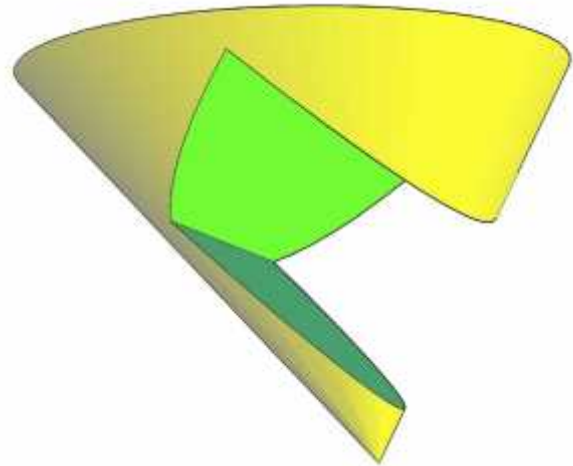

Figure 4a

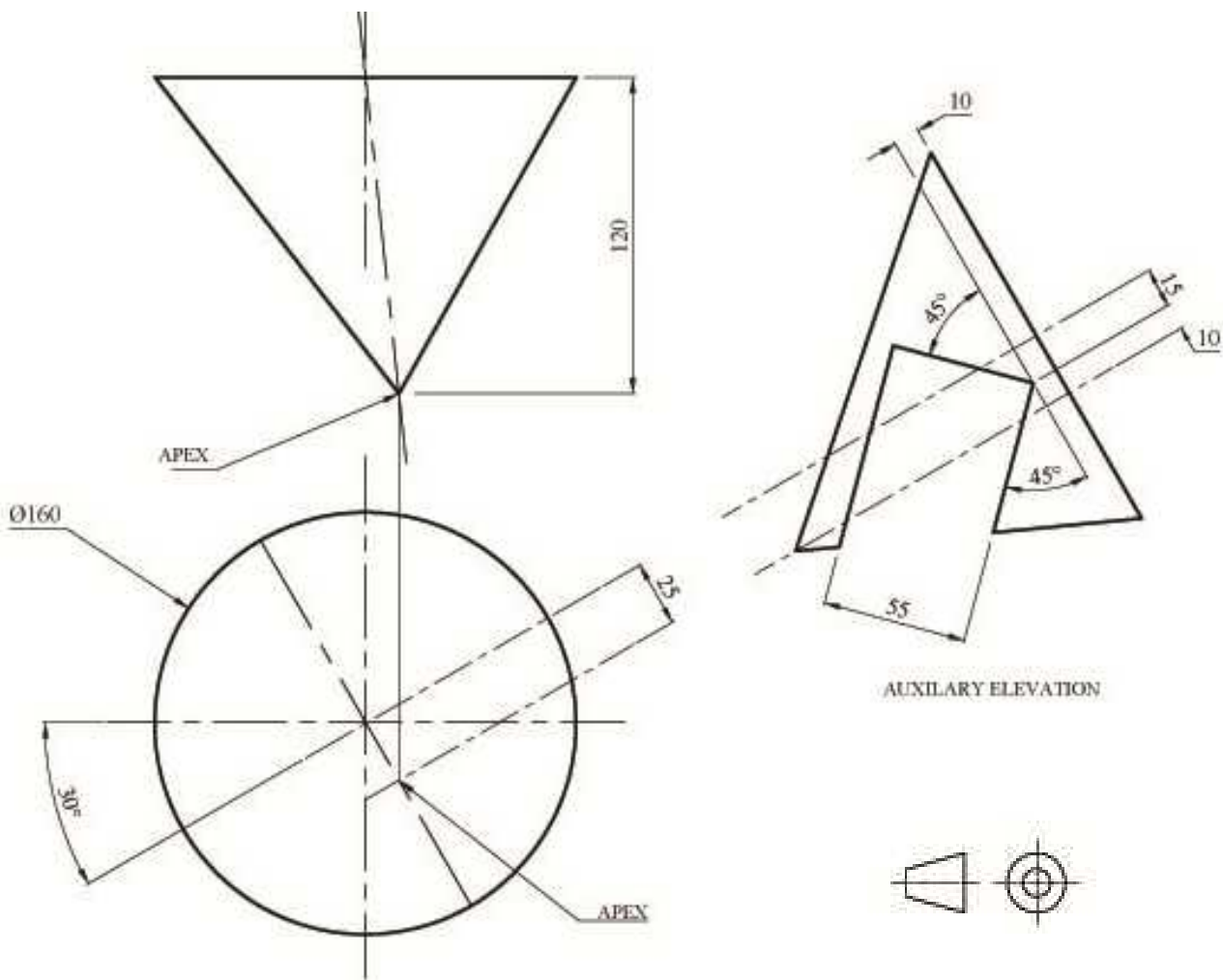

Figure 4b

Question 5

A modified punch is illustrated in Figure 5 a. The punch consists of a right cone and a regular hexagonal prism which serves as a handle.

- a) Draw, full size, the complete front elevation and plan, shown in Figure 5b. **(4 marks)**
- b) From the given views, project a first auxiliary plan on the line X_1-Y_1 . **(8 marks)**
- c) From the first auxiliary plan, project the second auxiliary view, on the line $X_2 - Y_2$. **(8 marks)**

Label your drawing, using letters/numbers in the appropriate positions to illustrate your construction lines. Select and trace a typical point through all the views.

Note: Hidden detail is NOT required in the second auxiliary view.



(20 marks total)

Figure 5a

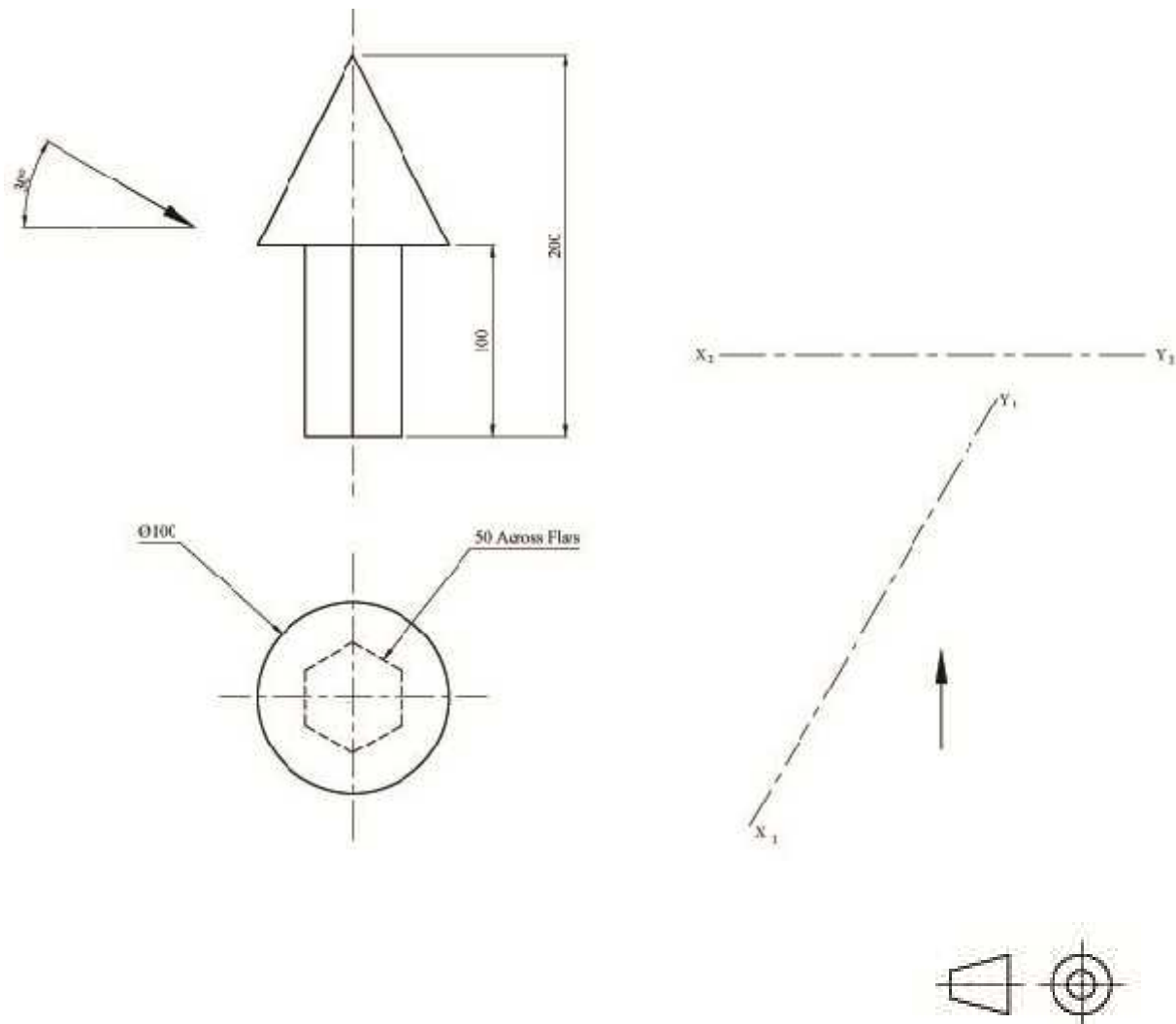

Figure 5b

Question 6

A design of a cylindrical cam is shown in Figure 6a. The roller is shown engaging in the groove of the cylinder.

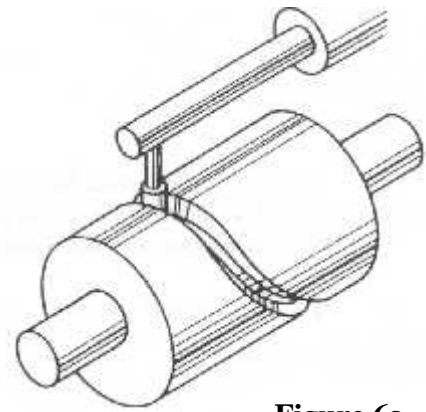

Figure 6a

- a. Draw, full size, the three views of the cam blank shown in Figure 6b. Include the surface development of the cylinder and annotate the radial lines around the circles if necessary. **(4 marks)**
- b. The specification of the motion displacement diagram is as follows:

Cam rotation (Anticlockwise)	Follower movement and types of motion
0° to 60°	Follower to dwell
60° to 150°	Follower to rise 60 mm with uniform acceleration
150° to 270°	Follower to rise 60 mm with uniform retardation
270° to 360°	Follower to fall to initial position with simple harmonic motion

Construct a suitable displacement diagram.

(7 marks)

- c. Project and draw the required cam profile on the two elevations, which will impart the stated motion to the follower. **(9 marks)**

(20 marks total)

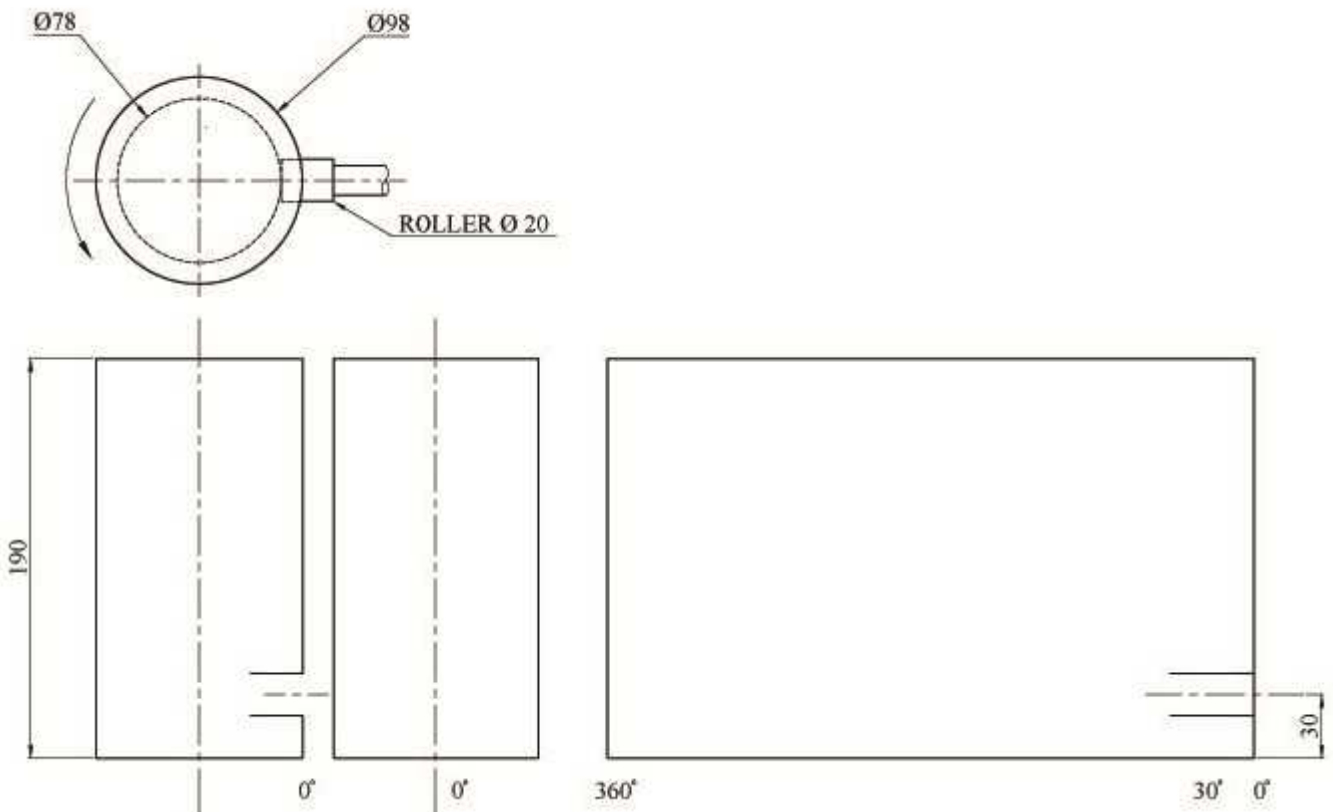
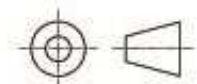

Figure 6b



MATRICULATION AND SECONDARY EDUCATION CERTIFICATE EXAMINATIONS BOARD
UNIVERSITY OF MALTA, MSIDA
MATRICULATION EXAMINATION
ADVANCED LEVEL
SEPTEMBER 2016

SUBJECT:	GRAPHICAL COMMUNICATION
PAPER NUMBER:	II
DATE:	3 rd September 2016
TIME:	9.00 a.m. to 12.05 p.m.

Directions to Candidates

Write your index number where indicated at the top of all drawing sheets.

Attempt **all** questions.

Programmable calculators **cannot** be used.

Unless otherwise stated:

- drawings should conform to B.S. or equivalent (ISO) standards;
- all dimensions are in millimetres;
- all answers are to be accurately drawn with instruments;
- all construction lines must be left on each solution;
- drawing aids may be used.

Dimensions not given should be estimated.

Careful layout and presentation are important.

Marks will be awarded for accuracy, clarity and appropriateness of constructions.

Colour/shading should be used where appropriate.

Mark allocations are shown in brackets.

Question 1 carries 34 marks. Questions 2, 3 and 4 carry 22 marks each.

Question 1

The front view, the end view and the plan of a living area are given in Figure 1. The furniture and accessories consist of a corner sofa with cushions, coffee table, two newspaper racks at the ends of the sofa, a carpet, curtains and a plant pot.

The wall adjacent to the room entrance has the following features: three small square recesses and one large rectangular recess which is lit by three spotlights.

A flight of steps outside the living area leads to the next floor level.

The given views constitute an integral part of the design process, but fail to convey a feeling of the **3D** proportions of the living area and the flight of steps.

You are to meet this requirement by drawing a **two-point estimated perspective view**. The viewing direction required is indicated by the arrows in the plan view.

- a) Using **three** preliminary sketches, explore alternative positions of the horizon line and identify the one which, in your opinion, best presents the spaciousness of the living area and the visible part of the steps. **(3 marks)**
- b) Based on the choice made in (i), produce the required illustration on a single side of an A2 size paper making the best use of the space available. **(26 marks)**
- c) Enhance your answer graphically using colours, tone and texture. **(5 marks)**

*You are not expected to apply colour/tone/texture to your whole illustration. You are advised to limit their use to a small area on each **different** item appearing in your illustration.*

(34 marks total)

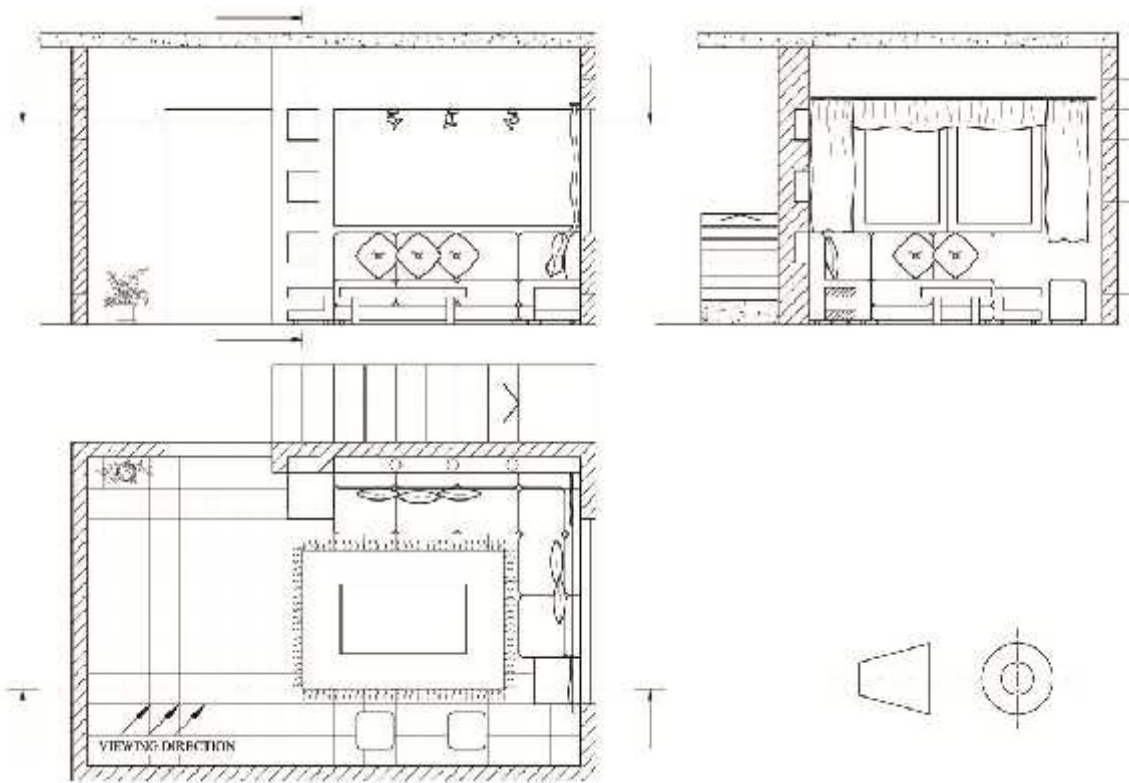

Figure 1

Question 2

Green Stamp is a non-profit organisation that uses science-based programs to empower consumers, purchasers, and companies to create a more sustainable world.

The organisation requires the design of a graphic symbol that will eventually be printed on the packaging of products that have been **certified** to be **environment friendly**.

You have been asked to submit your proposal for this certification stamp.

Your presentation has to follow the steps given below and organised as indicated in Figure 2.

a) **Written analysis**

Identify, using keywords/short phrases, the main parameters of the design brief. **(2 marks)**

b) **Graphical analysis**

Based on your response to (a), produce a series of preparatory sketches that illustrate your developing ideas. **(4 marks)**

c) **Graphical synthesis**

Clearly identify the elements in your sketches which you intend to use in the final drawing. **(2 marks)**

d) **Final realisation**

Produce your final solution in a frame of your chosen format. **(14 marks)**

(22 marks total)

GREEN STAMP CERTIFICATION SYMBOL

<p style="text-align: center; margin: 0;">WRITTEN ANALYSIS</p> <hr/> <hr/> <hr/>	<p style="text-align: center; margin: 0;">FINAL REALISATION</p> <div style="border: 1px solid black; height: 150px; width: 100%;"></div>
<p style="text-align: center; margin: 0;">GRAPHICAL ANALYSIS</p> <div style="border: 1px solid black; height: 100px; width: 100%;"></div>	
<p style="text-align: center; margin: 0;">GRAPHICAL SYNTHESIS</p> <hr/> <hr/> <hr/>	

UNIVERSITY OF MALTA

Figure 2

Question 3

Five orthographic views of an electric steam iron are given in Figure 3. To promote the design by a visual representation, you are requested to:

- a) draw a well-proportioned freehand **3-D sketch** to display the iron resting on the back with the sole plate (shiny metal hot surface) visible to the viewer; **(8 marks)**
- b) draw another well-proportioned pictorial sketch of the iron having the hot surface resting on a horizontal plane; **(8 marks)**
- c) use your preferred drawing medium or media to colour and shade **one** of your sketches. **(6 marks)**

Note: Marks will be awarded for proper use of colours to represent textures and forms.

(22 marks total)

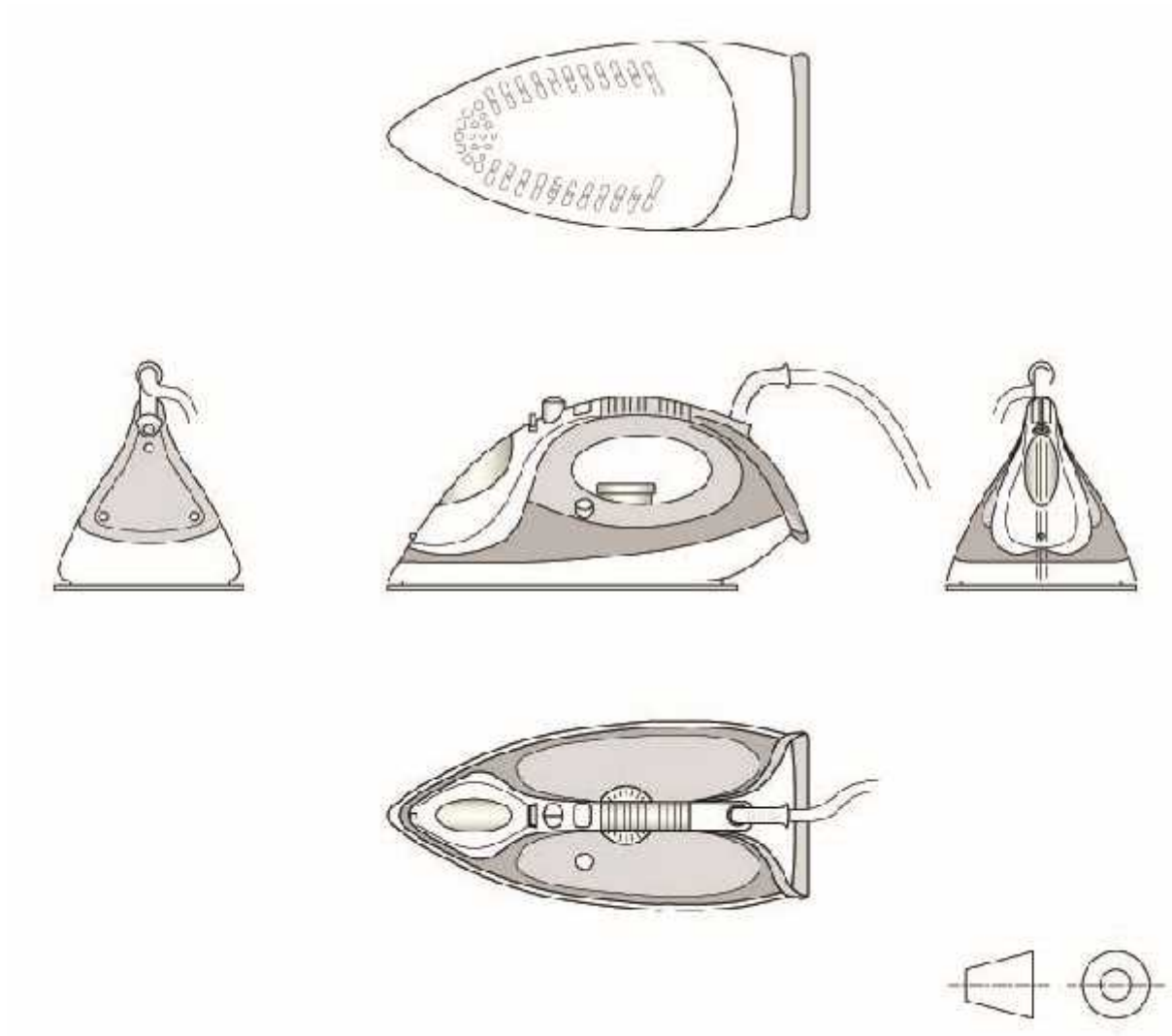

Figure 3

Question 4

A campaign to educate the general public to save water at home has been launched. An **Infographic Poster** to suggest five ways to save water is to be designed.

The suggested title of the poster is **SAVING WATER AT HOME**.

The five ways are listed below:

- 1) Fixing household **leaks** right away;
- 2) Washing only full loads of **dishes** and **laundry**;
- 3) Spending shorter time in the **shower**;
- 4) Turning off water while **brushing teeth**;
- 5) Using **Eco standard water saving appliances** (such as washing machines and bathroom units flushing).

You are required to design an infographic poster which incorporates the given list (1 to 5) in **textual form** and **graphic symbols** which you will have to create.

Notes:

- *Marks will be awarded for a suitable layout and the use of appropriate typefaces, colours and graphic symbols.*
- *The poster is expected to have a visual impact and carry the intended message clearly.*

(22 marks total)