

Question 1.

A quad bike rental information sign is given on the right. The sign consists of a profile of a quad bike and a crash helmet. The quad bike is composed of tangential lines and arcs. The crash helmet is composed of a part ellipse and tangential lines. Using the given starting lines, dimensioned drawing and notes:

- construct the inclined ellipse having a major axis of 60 mm and a minor axis of 50 mm; (4)
- locate, by construction, the focal points of the ellipse; (1)
- construct a tangent at point **X** to complete the crash helmet; (2)
- construct the profile of the quad bike; (11)
- locate, by construction, the points of tangencies and indicate by means of short dashes. (2)

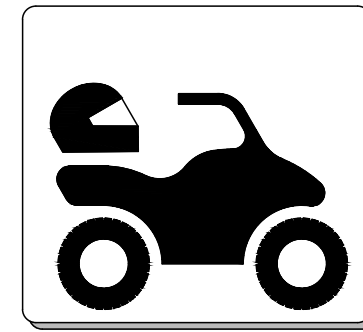

(Total: 20 marks)

NOTES

- A is the centre of arc R45 mm.
- B is the centre of arcs R45 mm and R75 mm.
- C is the centre of the R25 mm arc.
- D is the centre of the R 100 mm arc.
- Points of tangencies are denoted by means of short dashes as shown.
- RX and RY are to be found by construction.
- Leave all constructions, necessary to locate centres and points of tangencies, visible.

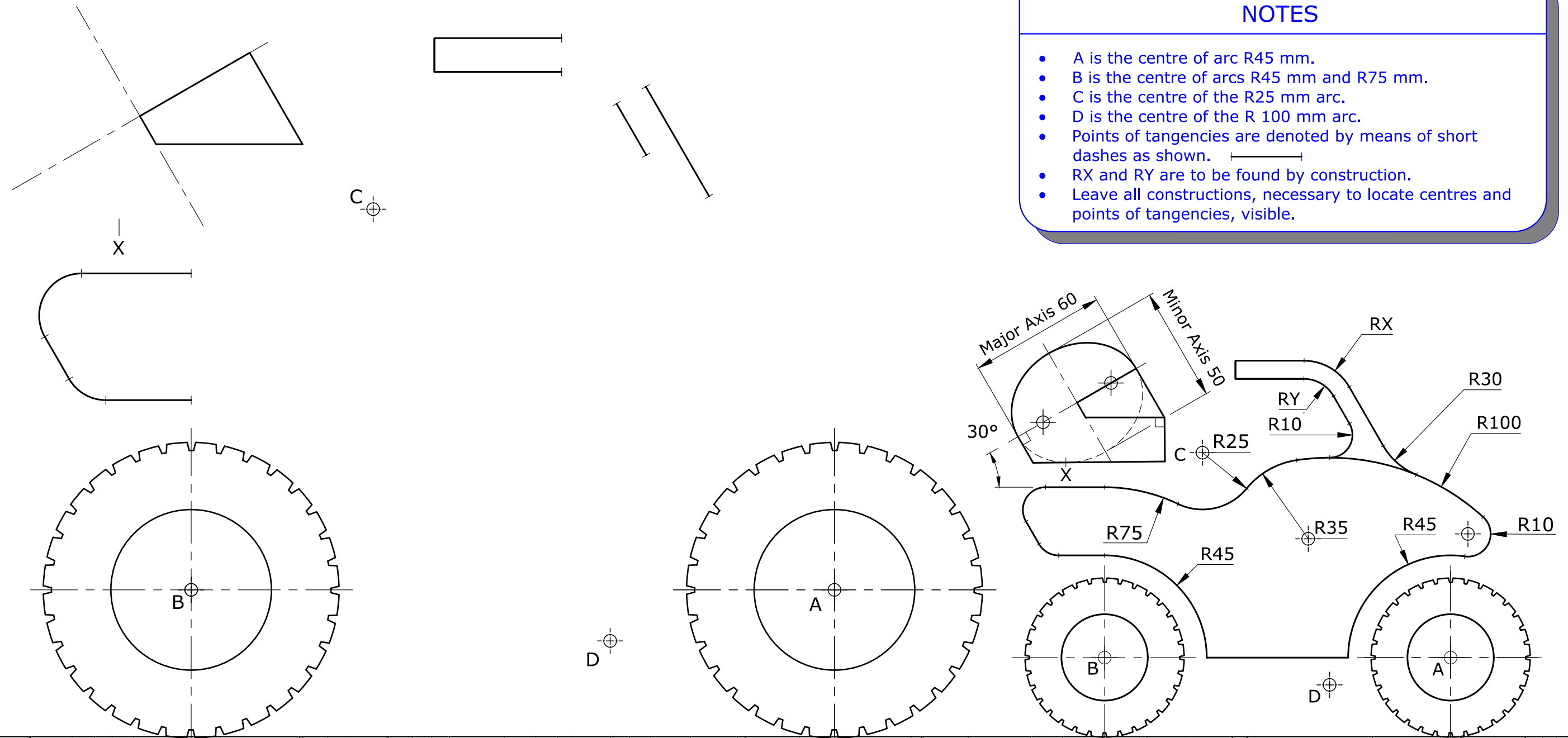

Question 2.

The simple mechanism shown below consists of:

- a slotted arm, pivoted on a wooden board, which is free to rotate about pivot O;
- a slider which is free to slide a distance of 90 mm from point A to point B of the slotted arm.

When the slotted arm rotates at uniform speed in a clockwise direction, the slider moves at uniform speed as follows:

1. from A to B during the first half revolution and;
2. from B to A during the second half revolution.

Point P lays on the centre of the slider.

Using the given starting lines, plot the locus of point P during one complete revolution of the arm.

Note: The first and last position of point P is at point A of the slotted arm as indicated in the starting lines.

(Total: 12 marks)

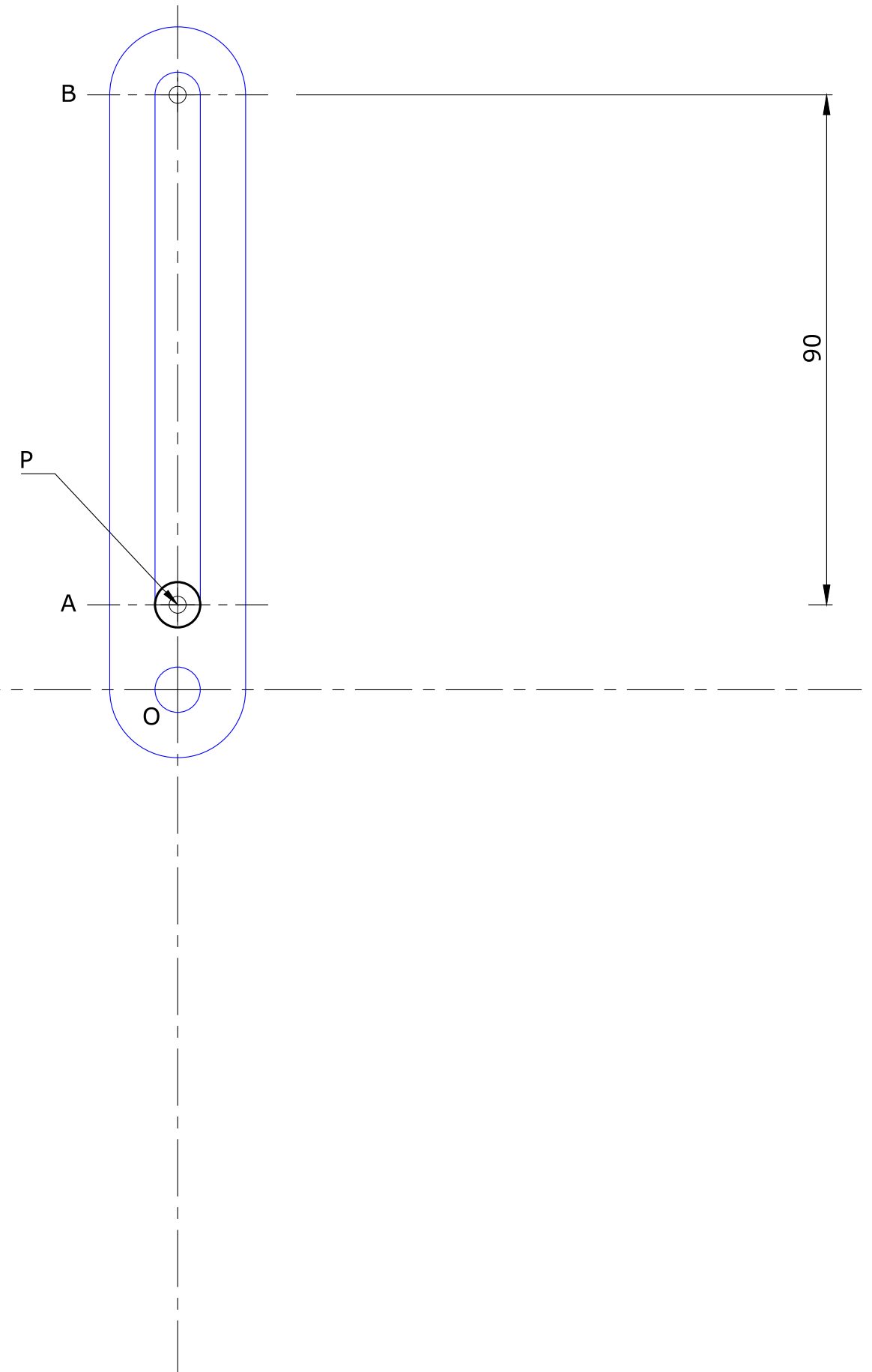
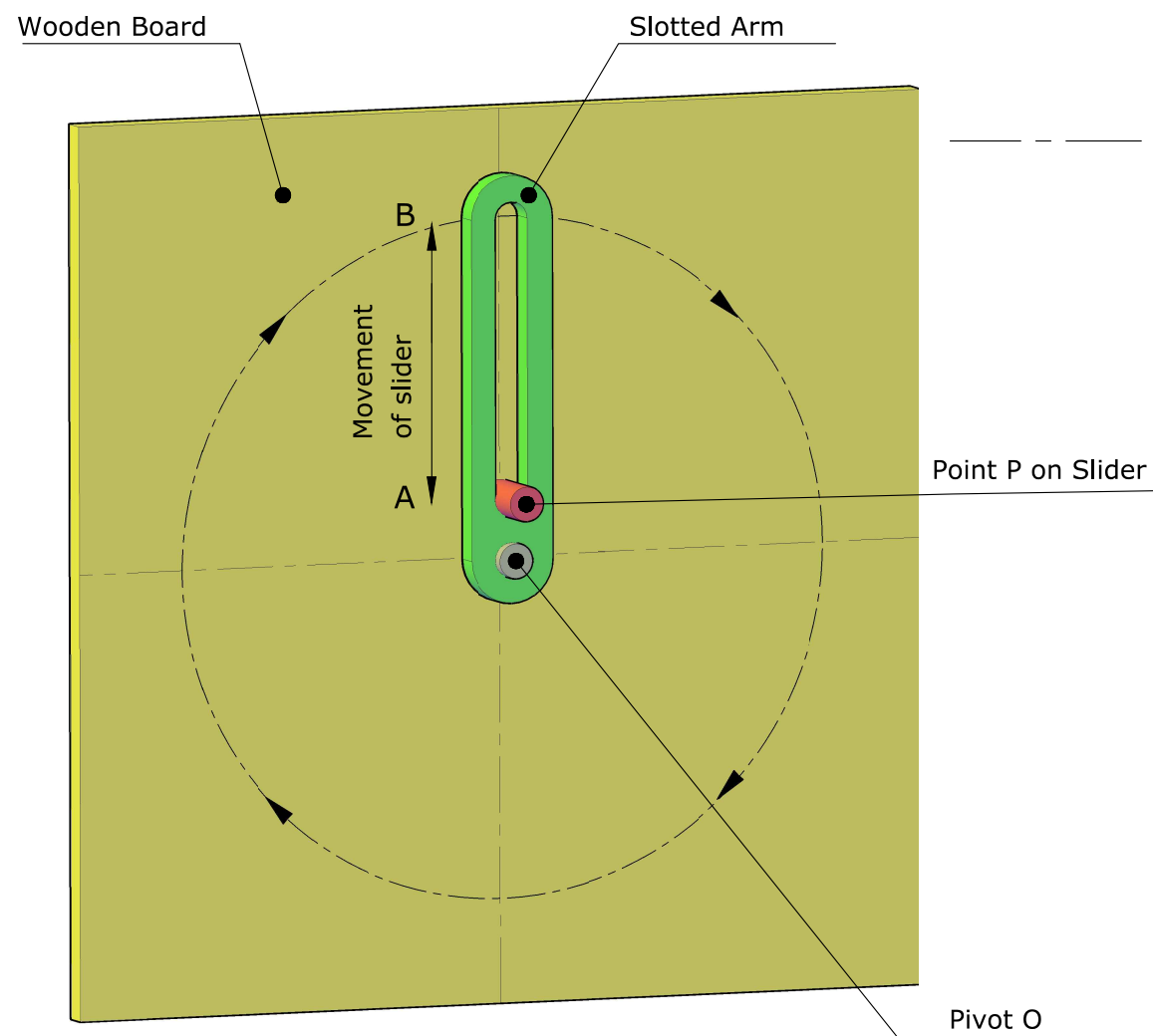

Question 3.

An illustration of a cast iron component is given below.
A plan and the profile of the front elevation are also given.

In the space provided complete a sectional front elevation on cutting plane D-D.

Notes:

- Show all centre lines.
- Do not show hidden details.

(Total: 14 marks)

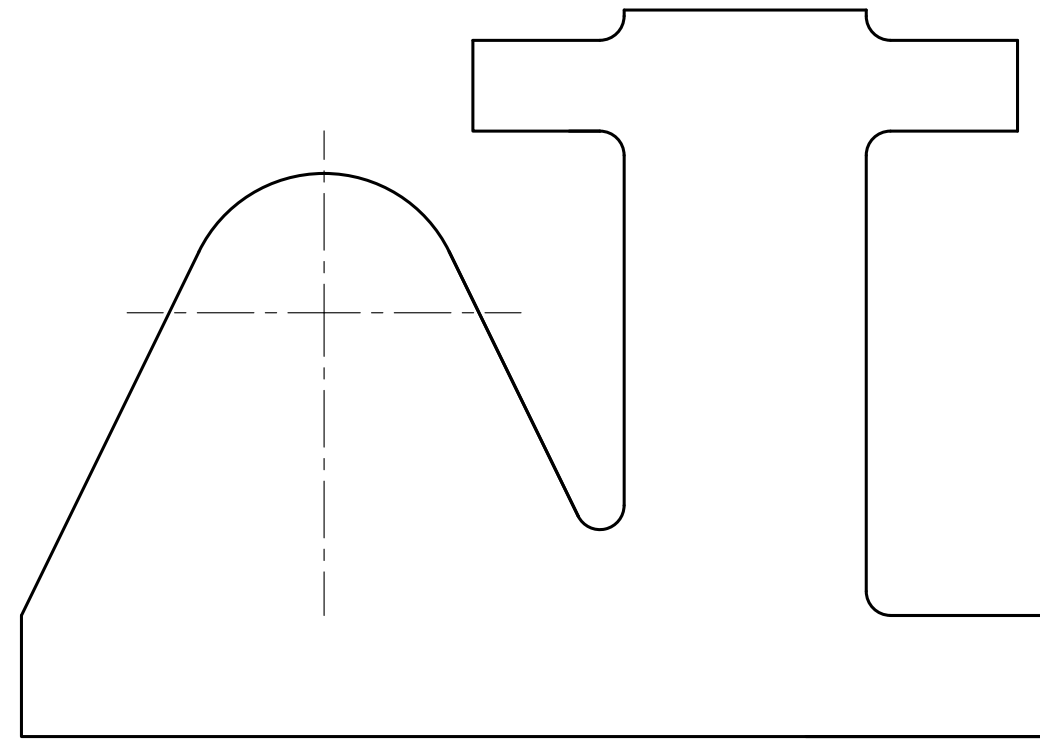
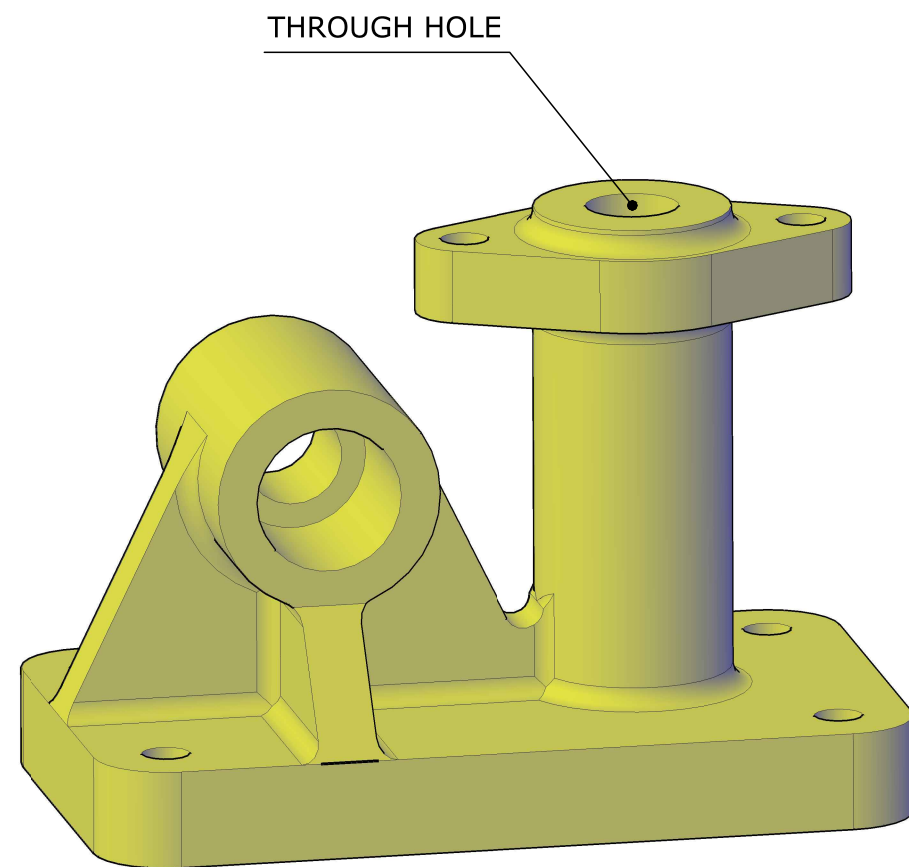

D - D

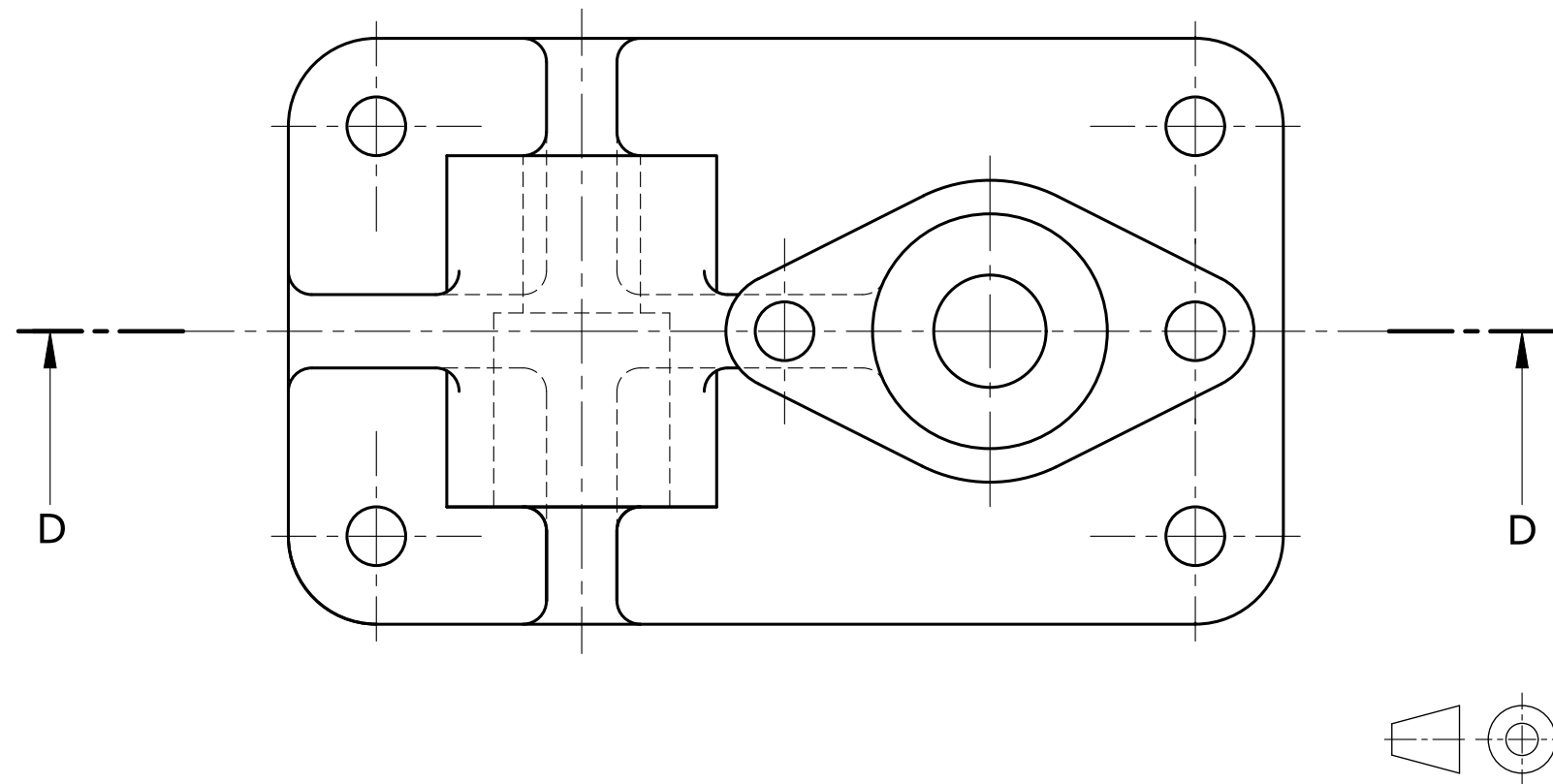

Question 4.

Two orthographic views and an illustration of a lantern are given.

The lantern is made up mainly of two truncated sheet metal pyramids, 'A' and 'B'.

In the space provided and on the given starting lines, construct the:

- a. true length of the slant edges of pyramid 'A'; (2)
- b. surface development of the truncated pyramid 'A'; (4)
- c. true length of the slant edges of pyramid 'B'; (2)
- d. surface development of the truncated pyramid 'B'. (8)

(Total: 16 marks)

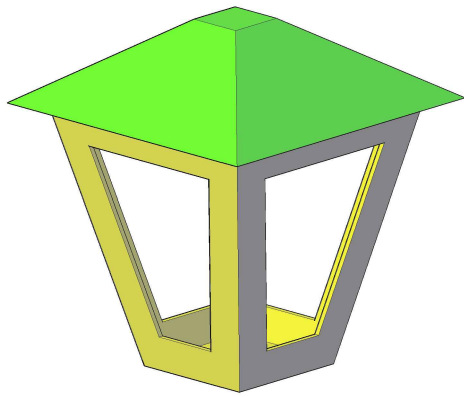

SURFACE DEVELOPMENT OF PYRAMID 'A'



SURFACE DEVELOPMENT OF PYRAMID 'B'

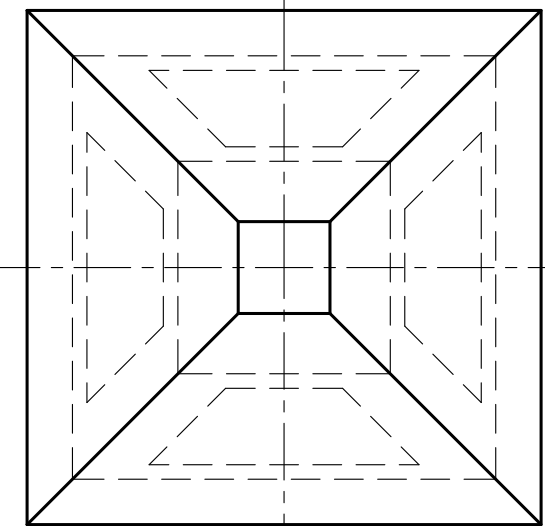
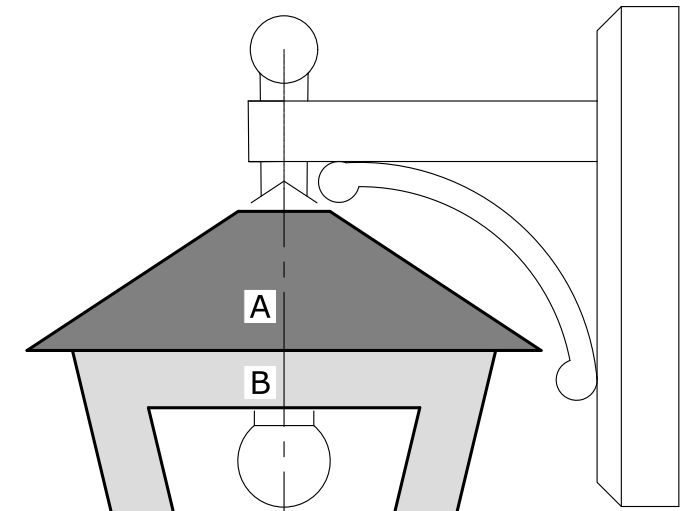
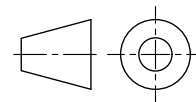

PLAN

Question 5.

Three orthographic views of a model garden deck are given below.
The starting lines and one of the flower pots in 60° / 30° planometric view are also given.

1. Complete the garden deck in planometric. (16)
2. Render, using coloured pencils, the flower pots. (2)

Notes:

- As indicated in the orthographic views, the flower pots and the pond are 5 mm deep.
- The material thickness of the garden shed is also 5 mm.
- An octagon 60 mm A/F is to be constructed in order to locate the remaining flower pots.

(Total: 18 marks)

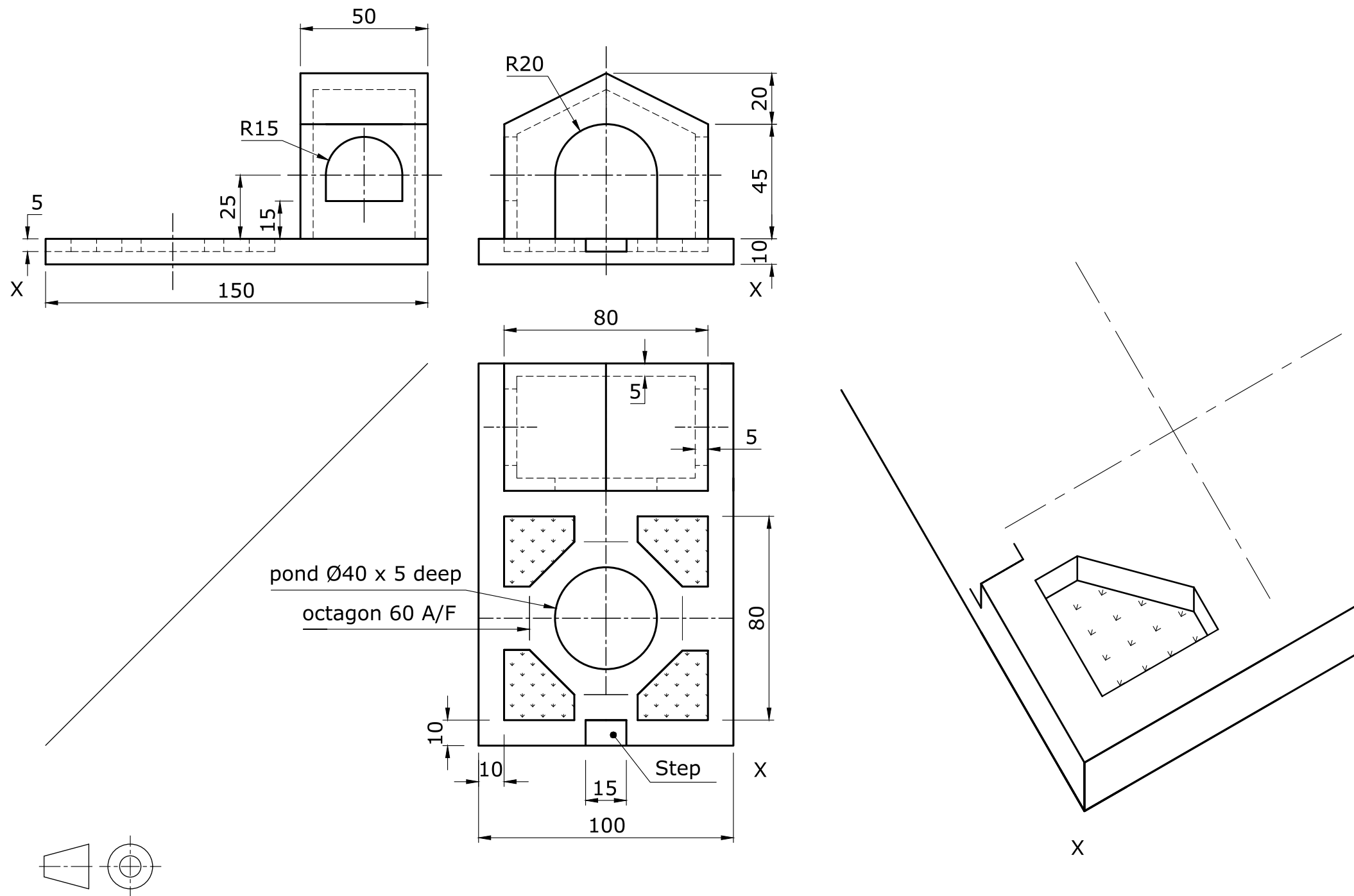

Question 6.

Two orthographic views and an isometric drawing of a basement laundry are given. The furnishings of the laundry consist of a floor, top and broom cupboards, a hand-washing basin, shelving, a fitted washing machine and a dryer.

Using the given starting lines, draw an estimated single-point perspective view of the laundry.

Notes:

- The viewing direction and vanishing point are indicated.
- The four tiles of the front right-hand corner, the ceiling and the basement door are given.

(Total: 20 marks)

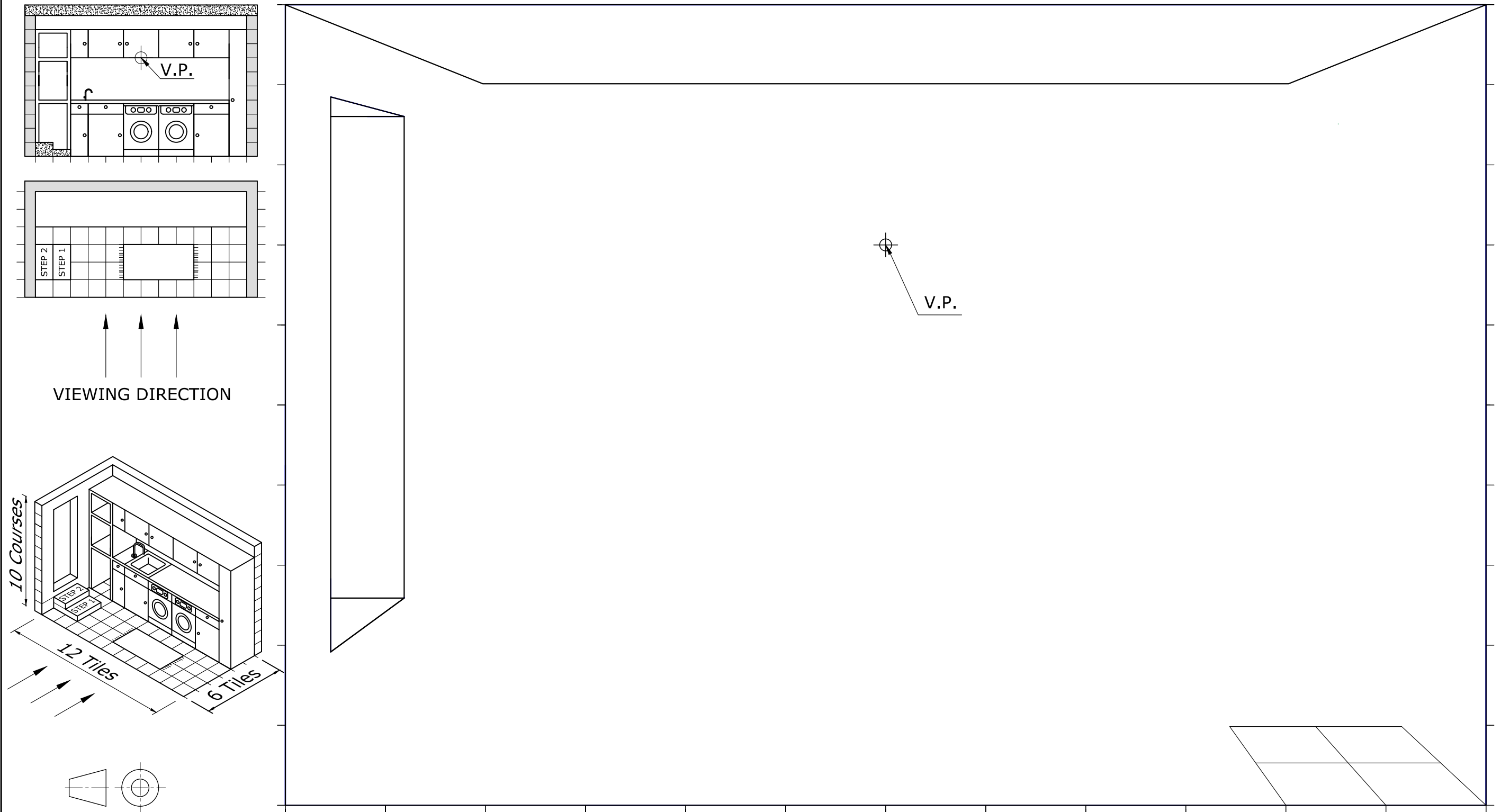

Question 1.

The following computer programme is written to create a coat of arms icon.

DATA: A = 50; B = 100; C = 150; D = 200; E = 250; F = 300; G = 350; H = 400; I = 450;
J = 500; K = 550; L = 600.

ACI 1: MOVE D,E; DRAW H,I; DRAW H,J; DRAW D,F;
ACI 3: MOVE D,J; DRAW E,K; DRAW F,J; DRAW G,K; DRAW H,J;
ACI 5: MOVE E,D; DRAW G,F; DRAW G,G; DRAW H,H; DRAW H,F; DRAW F,D;
ACI 7: MOVE D,B; DRAW D,A; DRAW A,A; DRAW B,B; DRAW A,C; DRAW C,C;
ACI 7: MOVE H,D; DRAW C,D; DRAW C,B; DRAW H,B;
ACI 7: MOVE E,D; DRAW D,E; DRAW D,K; DRAW H,K;
ACI 7: MOVE H,J; DRAW D,J;
ACI 7: MOVE D,A; DRAW C,B;
ACI 7: MOVE H,A; DRAW G,B.

MIRROR the plotted design, using the vertical centre line as the mirror line (line of symmetry).

The **DATA** statement specifies the numeric values (in pixels) of given variables. **MOVE**, positions the cursor at a new location without drawing a line. **DRAW** draws a line from a current location to a new location. The instruction **ACI No.** makes the images that follow the instruction, appear in the colour associated with the number. The computer responds to the following colour commands:

COLOUR	RED	GREEN	BLUE	BLACK
ACI No.	1	3	5	7

The starter sheet below shows a pre-printed grid representing an 800 x 600 graphical display.

Use the grid to plot the image produced by this programme.

(Total: 10 marks)

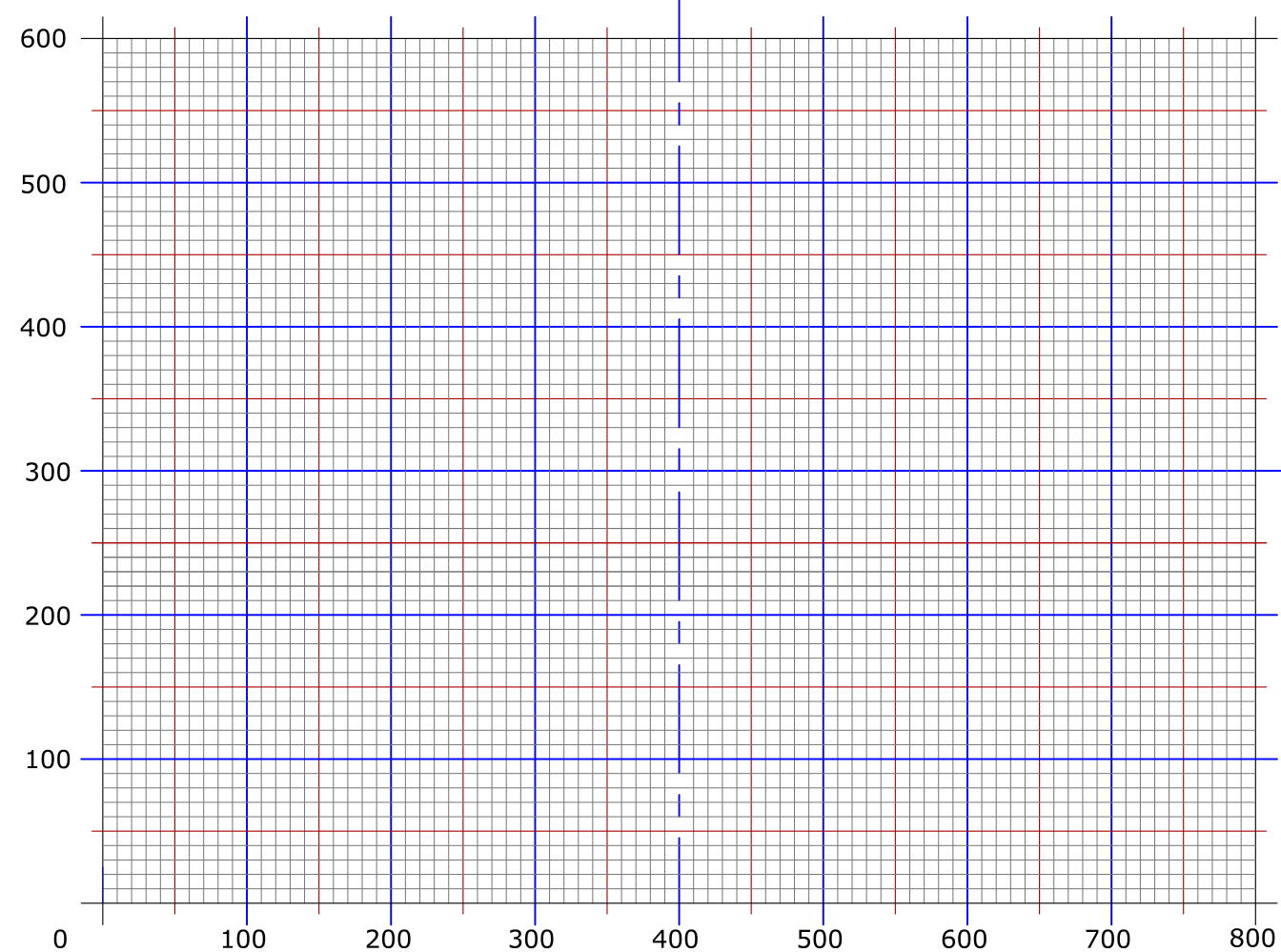

Question 2.

Four steel cables are attached to an eyebolt as shown. The eyebolt is anchored to a rock.

- Draw a freehand sketch of the vector diagram. (2)
- Construct the vector diagram. (5)
- State the magnitude and direction of the resultant. (2)
- State the angle of the resultant with the horizontal. (1)

Note: Use a scale of 10 mm representing 10 N.

(Total: 10 marks)

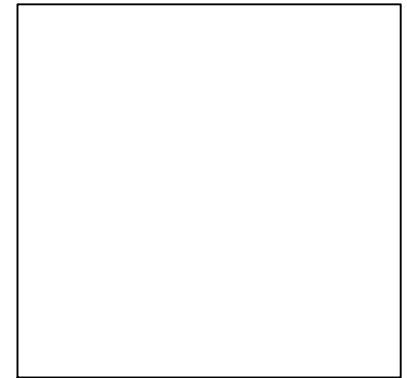
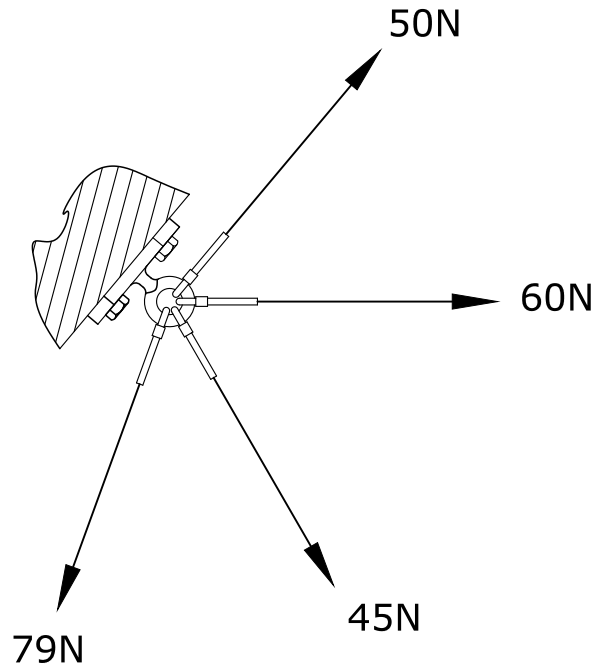

Freehand sketch

MAGNITUDE OF RESULTANT N

ANGLE OF RESULTANT WITH THE HORIZONTAL = °

Question 3.

A study was carried out to investigate the number of students that preferred different reading media. The study was carried out between 2014 and 2017. A table, a line graph and a key (given below) were partly prepared to reveal the findings of the study.

You are required to complete the information graphic by:

- a. designing the missing icons in the given Table A (use space for preparatory sketches); (6)
- b. completing the data in Table A for books and e-books; (3)
- c. completing the Line graph for magazines and online reading; (3)
- d. colour coding Table A and the Line graph to match the Key. (2)



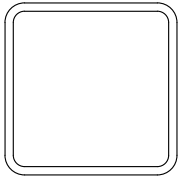
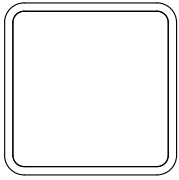
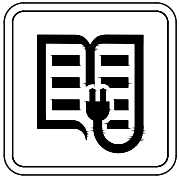



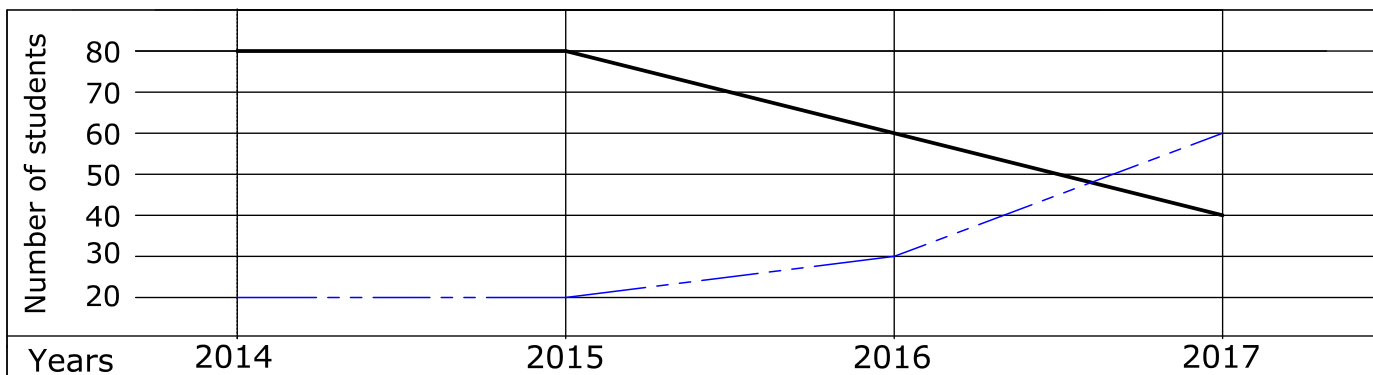

(Total: 14 marks)

Table A: Popularity of reading media amongst young readers				
reading media and their icons				
	Books	Magazines	Online reading	e-books
2014		40	30	
2015		60	40	
2016		40	70	
2017		20	80	

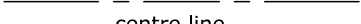
Line graph:

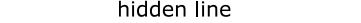

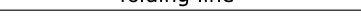
Key:

reading media	line type	colour
books	 bold line	 black
magazines	 centre line	 red
online reading	 hidden line	 green
e-books	 folding line	 blue

Preparatory sketches

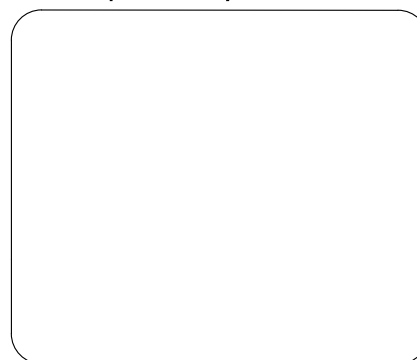

Question 4.

Two orthographic views and an exploded view of a plastic toy robot are given.

In the space provided, draw:

- a. a well-proportioned Isometric freehand sketch of the assembled robot; (11)
- b. colour and shade your drawing. (4)

Note: Make the best use of the available space.

(Total: 15 marks)

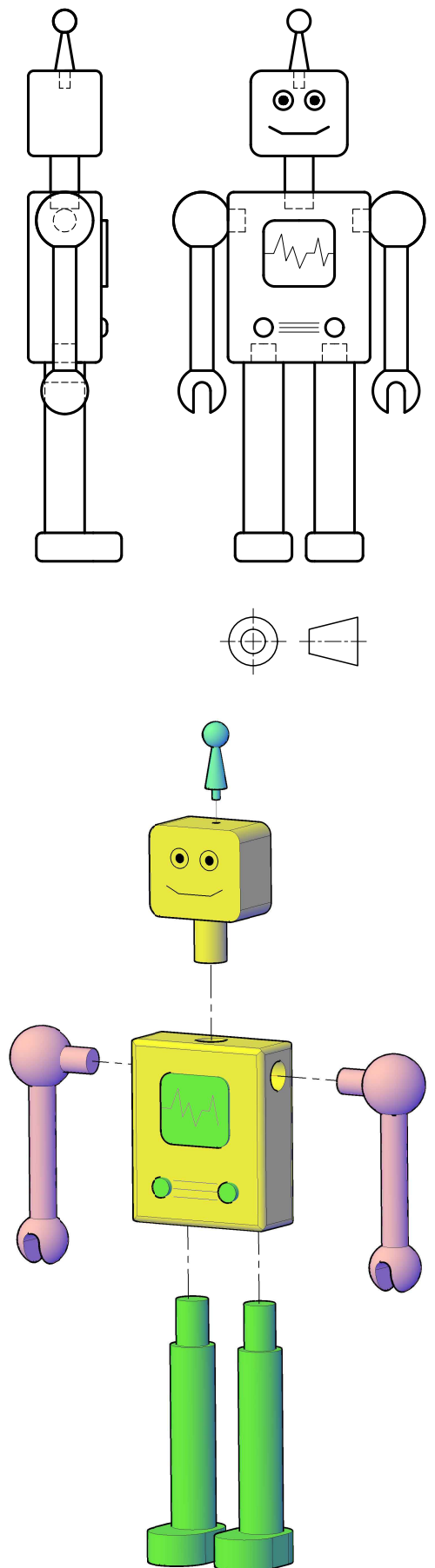

Question 5.

A Barber Pole which has red, white and blue helical stripes is shown in Figure A.
The printed adhesive tape given below is to be wrapped around this pole, thus forming the helical stripes.

Using the starting lines given on the Barber Pole:

- a. construct the four helices shown in Figure B; (10)
- b. line in with a bold outline the visible parts of the helices (as shown in Figure B); (2)
- c. colour and shade the indicated stripes (as shown in Figure A). (3)

Notes:

- Do not show hidden details.
- Leave all construction lines visible.

(Total: 15 marks)

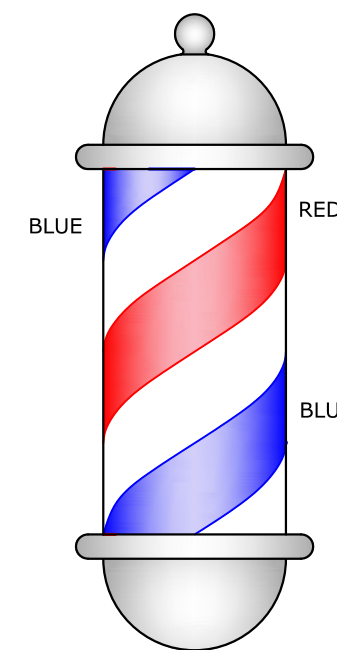
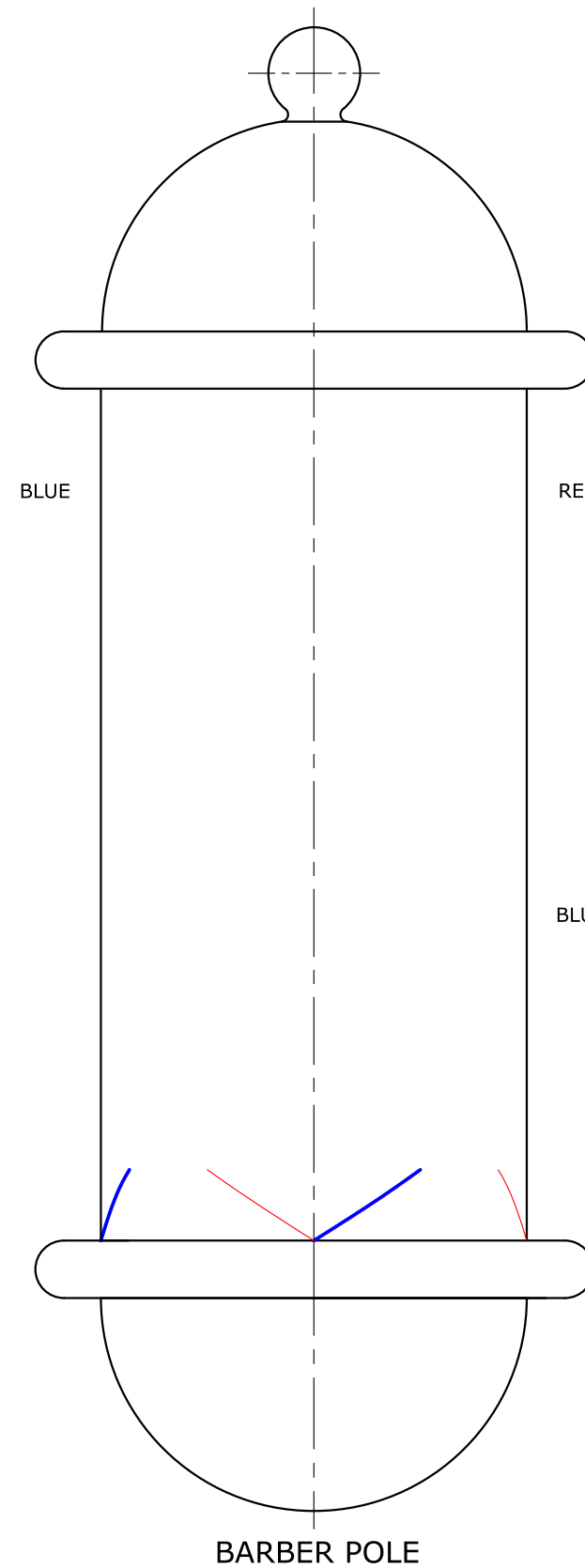
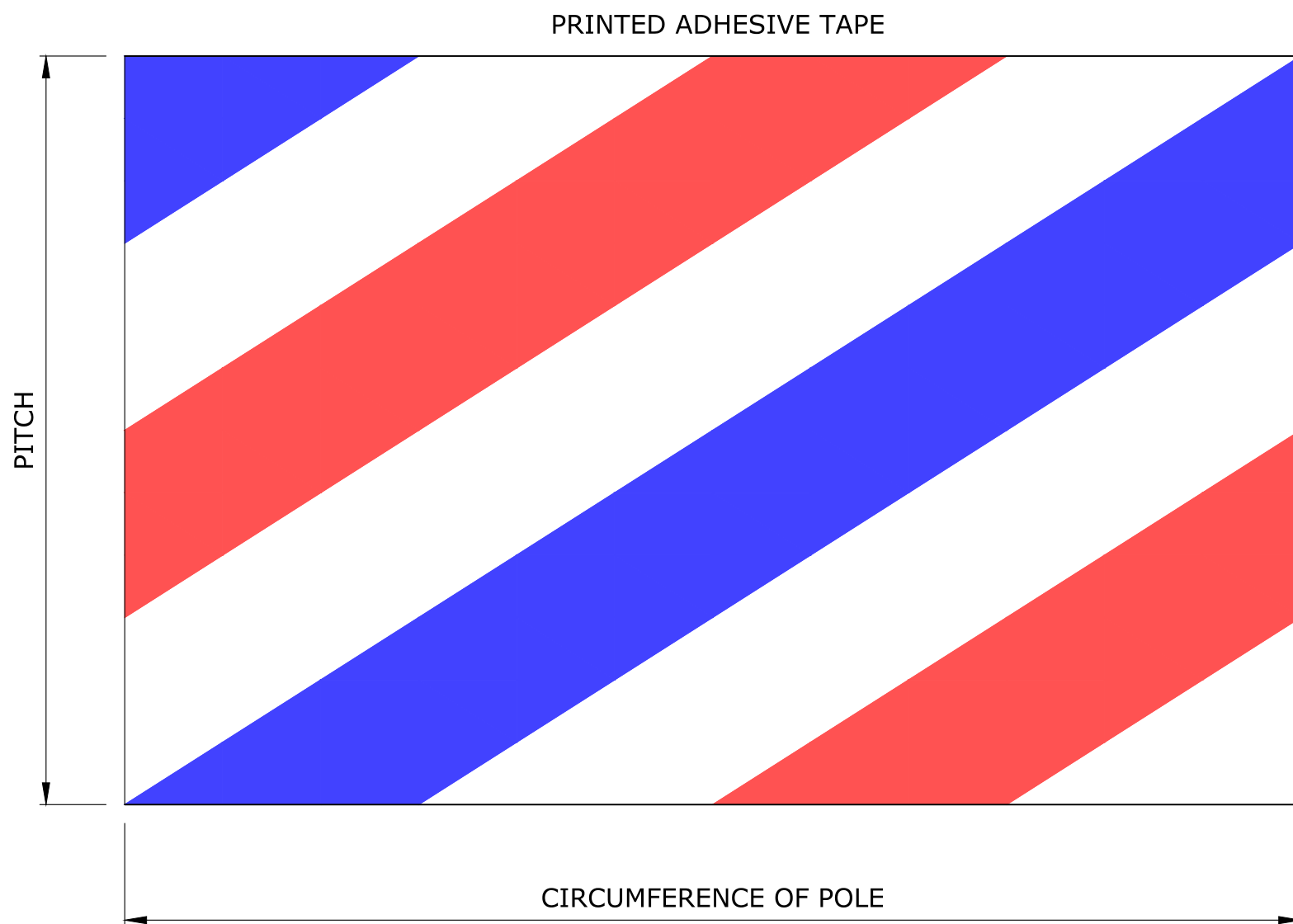

FIGURE A

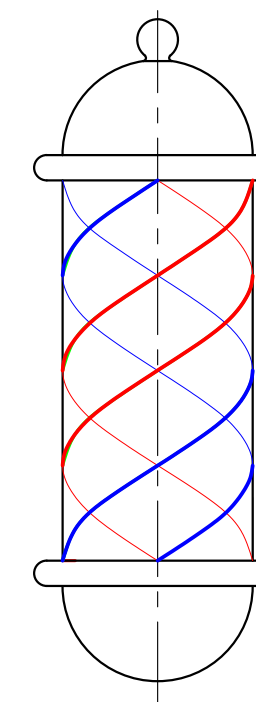

FIGURE B

Question 6.

The upper part of a police academy trophy is shown in the illustration below. This consists of a metal cylinder intersected by a prismatic shield, producing a hole in the cylinder. The front elevation, plan and an incomplete end elevation are given. You are required to:

- a. complete, by projection, the end elevation showing the resulting curves of intersection; (8)
- b. project the surface development of the cylinder, showing clearly the hole resulting from the intersection with the shield. (10)

Note: Place the joint line along J-J.

(Total: 18 marks)

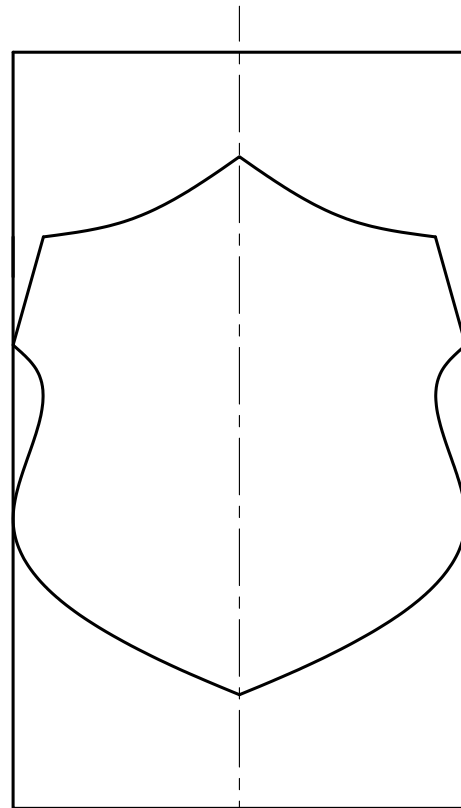

FRONT ELEVATION

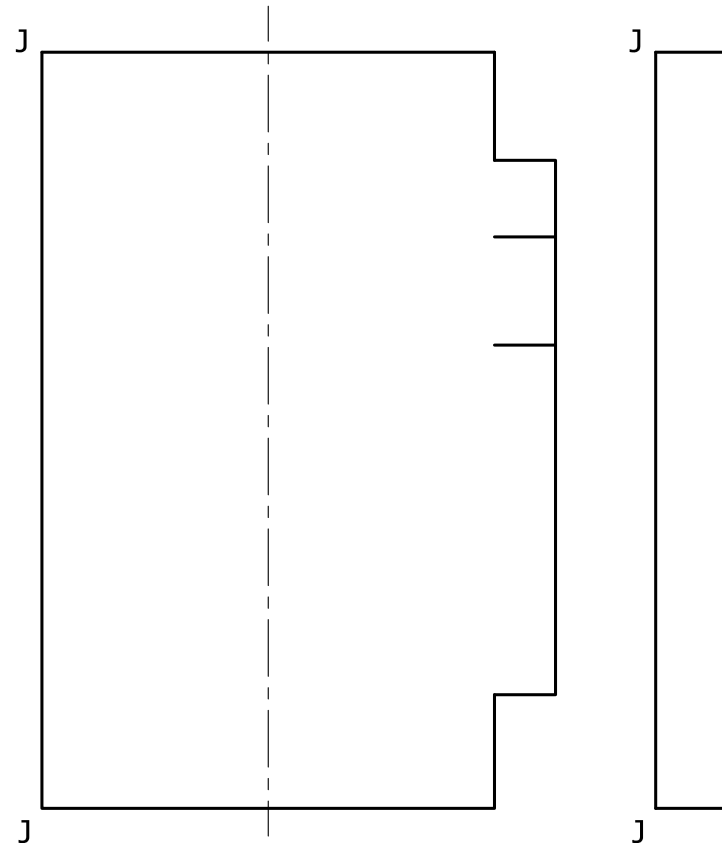

END ELEVATION

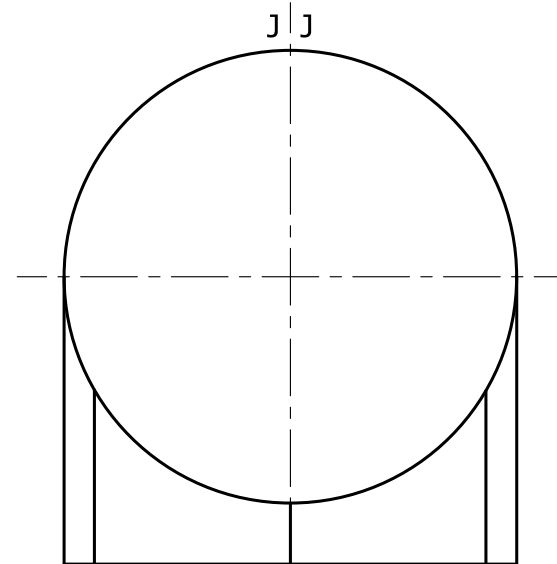

PLAN

SURFACE DEVELOPMENT OF THE CYLINDER

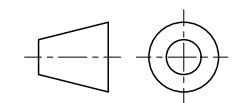
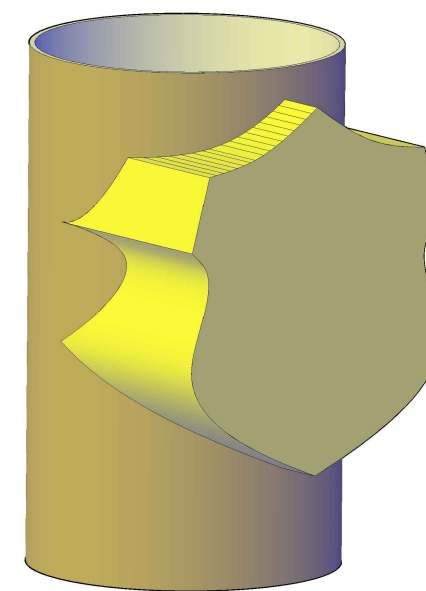

Question 7.

The illustration below shows a variety of large soft playing blocks that can be arranged in different setups. In this case, a tunnel-slide has been formed with blocks A, B, C and D.

A scaled down incomplete front elevation, a plan and an exploded view of the toddler tunnel-slide are given.

- a. Complete the front elevation. (5)
- b. On the given $X_1 - Y_1$ line, project an auxiliary elevation of the arrangement as seen from the direction of arrow A. (13)

Notes:

- The steps of block D are 15 mm high.
- Block C is 45 mm high.
- The points of tangencies of block A are indicated by short dashes.
- Do not draw hidden details.

(Total: 18 marks)

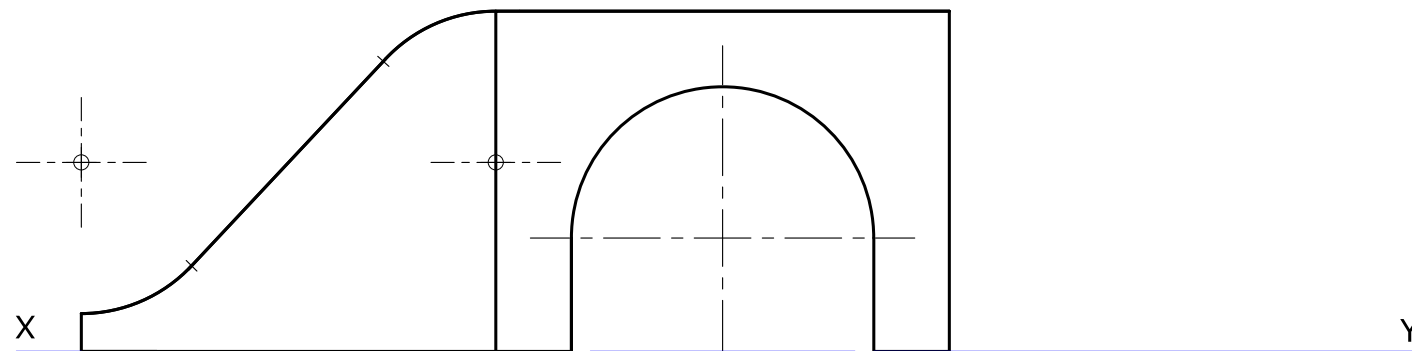
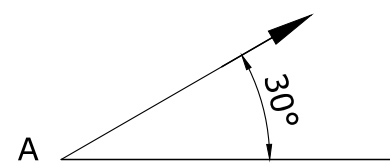
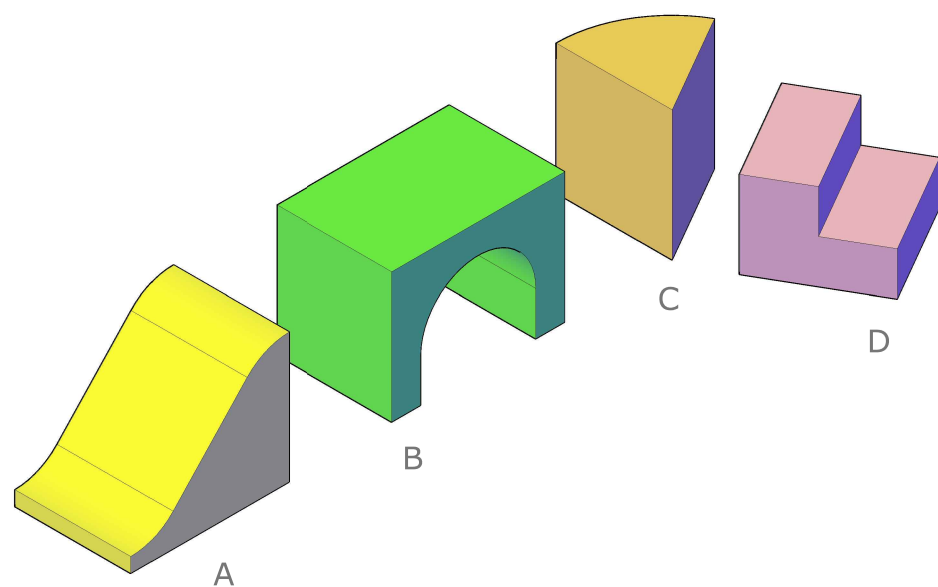

FRONT ELEVATION

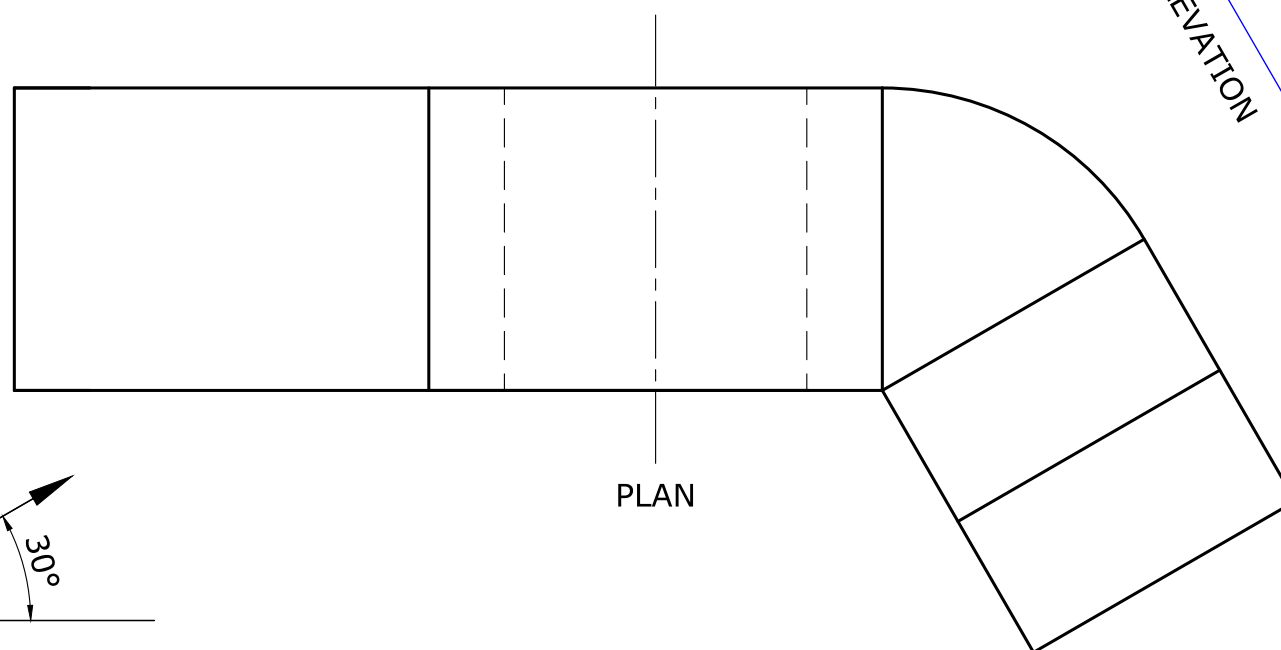

PLAN

AUXILIARY ELEVATION

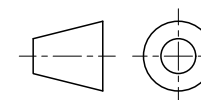

Question 1.

The following computer programme is written to create a coat of arms icon.
 DATA: A = 50; B = 100; C = 150; D = 200; E = 250; F = 300; G = 350; H = 400; I = 450;
 J = 500; K = 550; L = 600.
 ACI 1: MOVE D,E; DRAW H,I:
 ACI 5: MOVE E,D; DRAW H,G:
 ACI 7: MOVE D,B; DRAW D,A; DRAW A,A; DRAW B,B; DRAW A,C; DRAW C,C:
 ACI 7: MOVE H,D; DRAW C,D; DRAW C,B; DRAW H,B:
 ACI 7: MOVE E,D; DRAW D,E; DRAW D,K; DRAW H,K:
 ACI 7: MOVE H,J; DRAW D,J:
 ACI 7: MOVE D,A; DRAW C,B:
 ACI 7: MOVE H,A; DRAW G,B.

MIRROR the plotted design, using the vertical centre line as the mirror line (line of symmetry).

The **DATA** statement specifies the numeric values (in pixels) of given variables. **MOVE**, positions the cursor at a new location without drawing a line. **DRAW** draws a line from a current location to a new location. The instruction **ACI No:** makes the images that follow the instruction, appear in the colour associated with the number. The computer responds to the following colour commands:

COLOUR	RED	BLUE	BLACK
ACI No.	1	5	7

The starter sheet below shows a pre-printed grid representing an 800 x 600 graphical display. Use the grid to plot the image produced by this programme.

(Total: 10 marks)

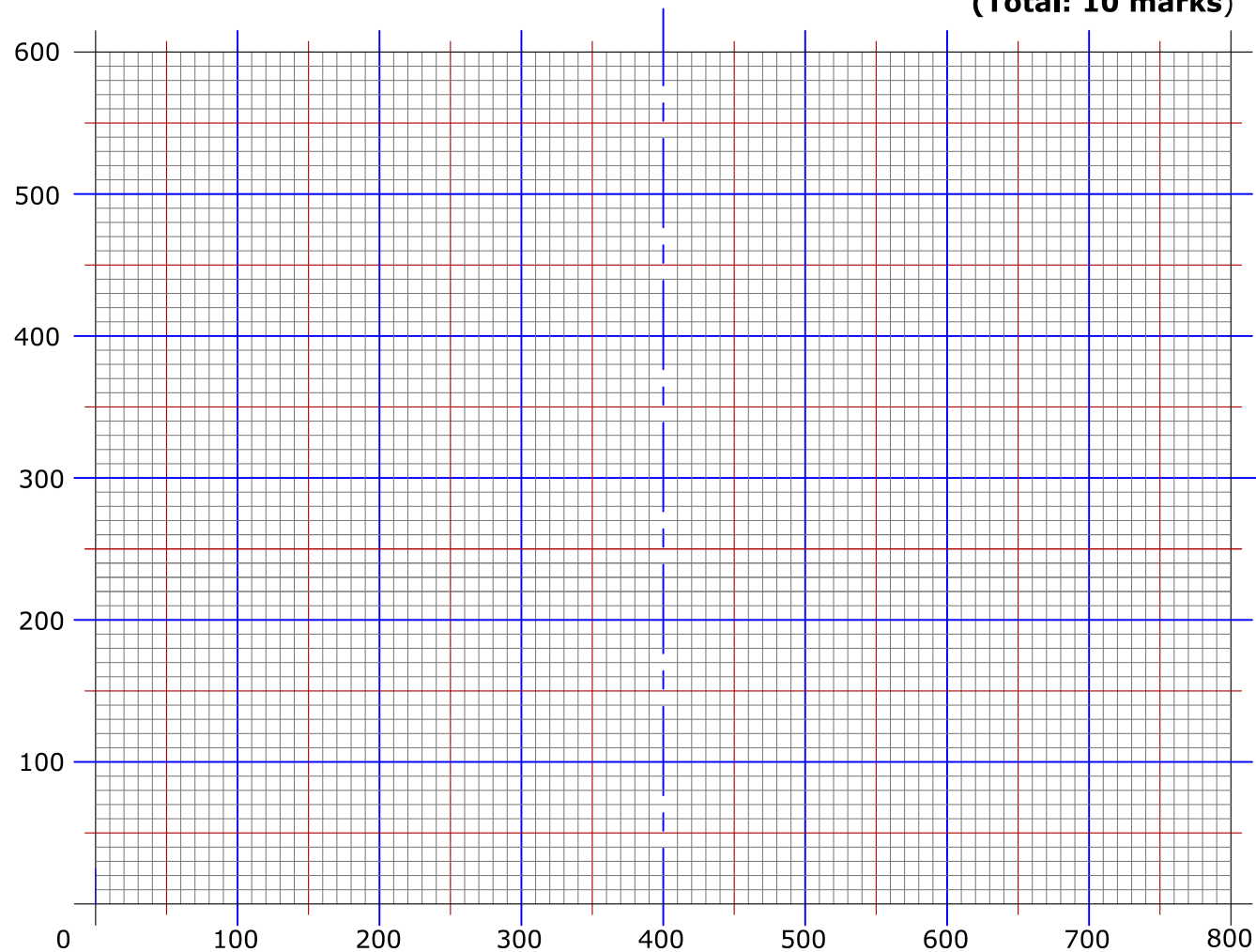

Question 2.

Three steel cables are attached to an eyebolt as shown. The eyebolt is anchored to a rock.

- a. Draw a freehand sketch of the vector diagram. (2)
- b. Construct the vector diagram. (5)
- c. State the magnitude and direction of the resultant. (2)
- d. State the angle of the resultant with the horizontal. (1)

Note:

Use a scale of 10 mm representing 10 N.

(Total: 10 marks)

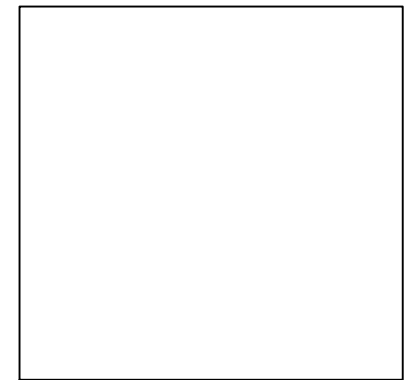

Freehand sketch

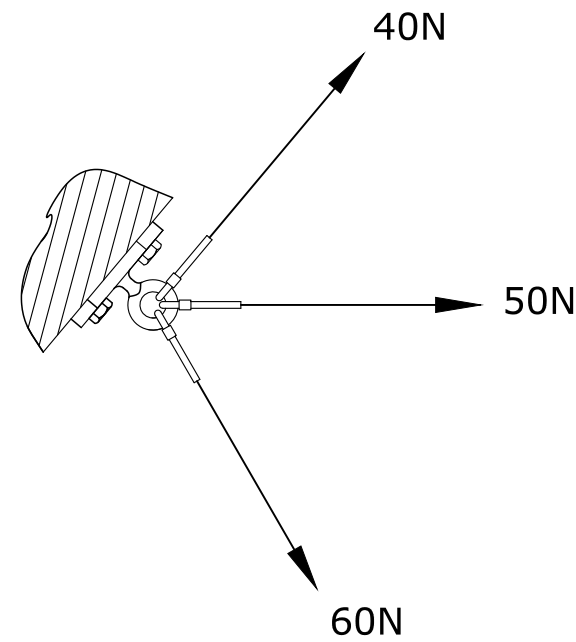

MAGNITUDE OF RESULTANT N

ANGLE OF RESULTANT WITH THE HORIZONTAL

Question 3.

A trend survey study was carried out to investigate the number of students that preferred different reading media over a number of years. A table, a line graph and a key, given below, were partly prepared to reveal the findings of the survey.

You are required to complete the information graphic by:

- a. designing the missing icon in the given Table A (use space for preparatory sketches); (6)
- b. completing the data in Table A for e-books; (3)
- c. completing the Line graph for online reading; (3)
- d. colour coding the Table A and the Line graph to match the Key. (2)



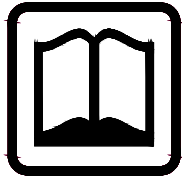
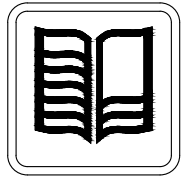
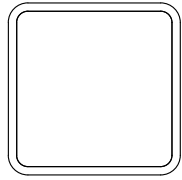
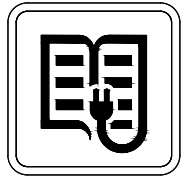

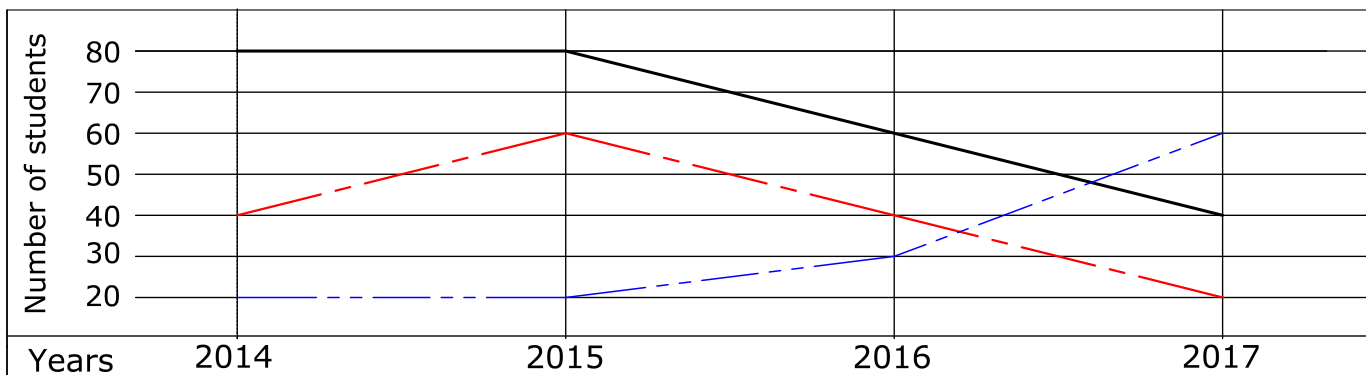

(Total: 14 marks)

Table A: Popularity of reading media amongst young readers				
reading media and their icons	 Books	 Magazines	 Online reading	 e-books
2014	80	40	30	
2015	80	60	40	
2016	60	40	70	
2017	40	20	80	

Line graph:

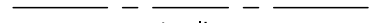

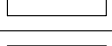
Key:

reading media	line type	colour
books	 bold line	 black
comic magazines	 centre line	 red
online reading	 hidden line	 green
e-books	 folding line	 blue

Preparatory sketches



Question 4.

Two orthographic views and an exploded view of a plastic toy robot are given.

In the space provided and using the given starting lines:

- a. draw a well-proportioned Oblique freehand sketch of the assembled robot; (11)
- b. colour and shade your drawing. (4)

Note: Make the best use of the available space.

(Total: 15 marks)

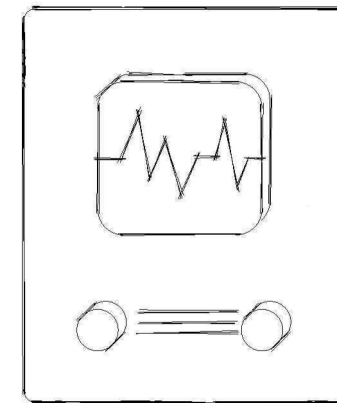
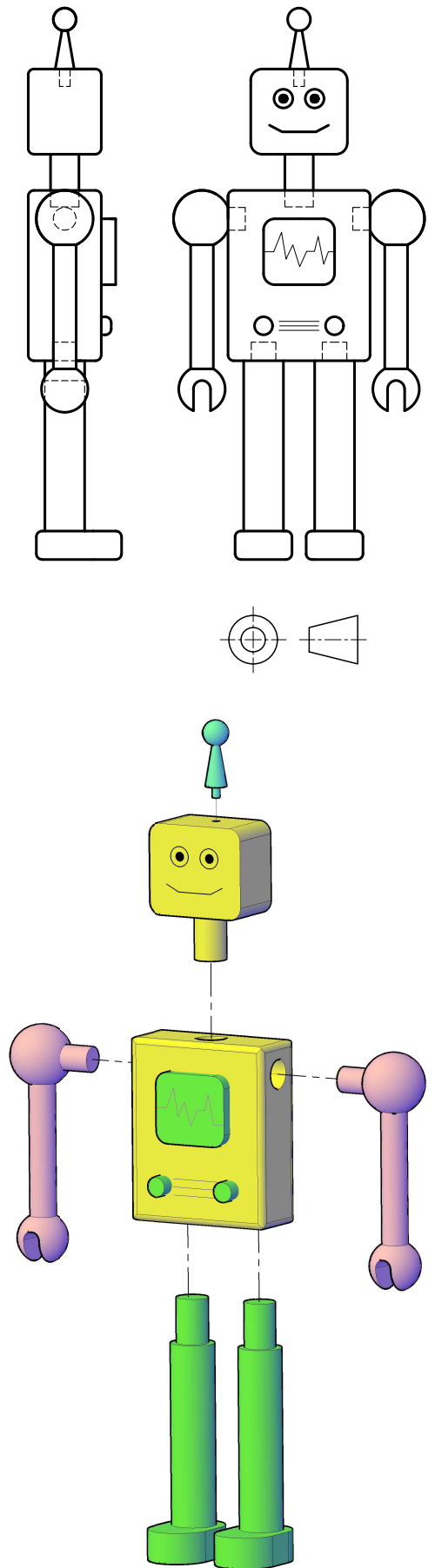

Question 5.

A Barber Pole which has red, white and blue helical stripes is shown in Figure A. The printed adhesive tape given below is to be wrapped around the pole, thus forming the helical stripes shown in the illustration.

On the starting lines given on the Barber Pole:

- a. construct the four helices shown in Figure B; (10)
- b. line in with a bold outline the visible parts of the helices (as shown in Figure B); (2)
- c. colour and shade the indicated stripes (as shown in Figure A). (3)

Notes:

- Do not show hidden details.
- Leave all construction lines visible.

(Total: 15 marks)

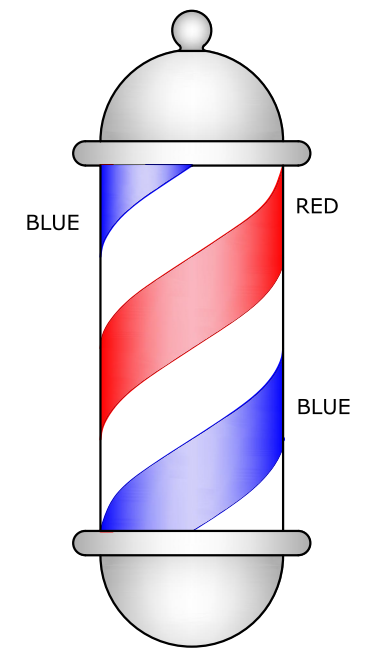
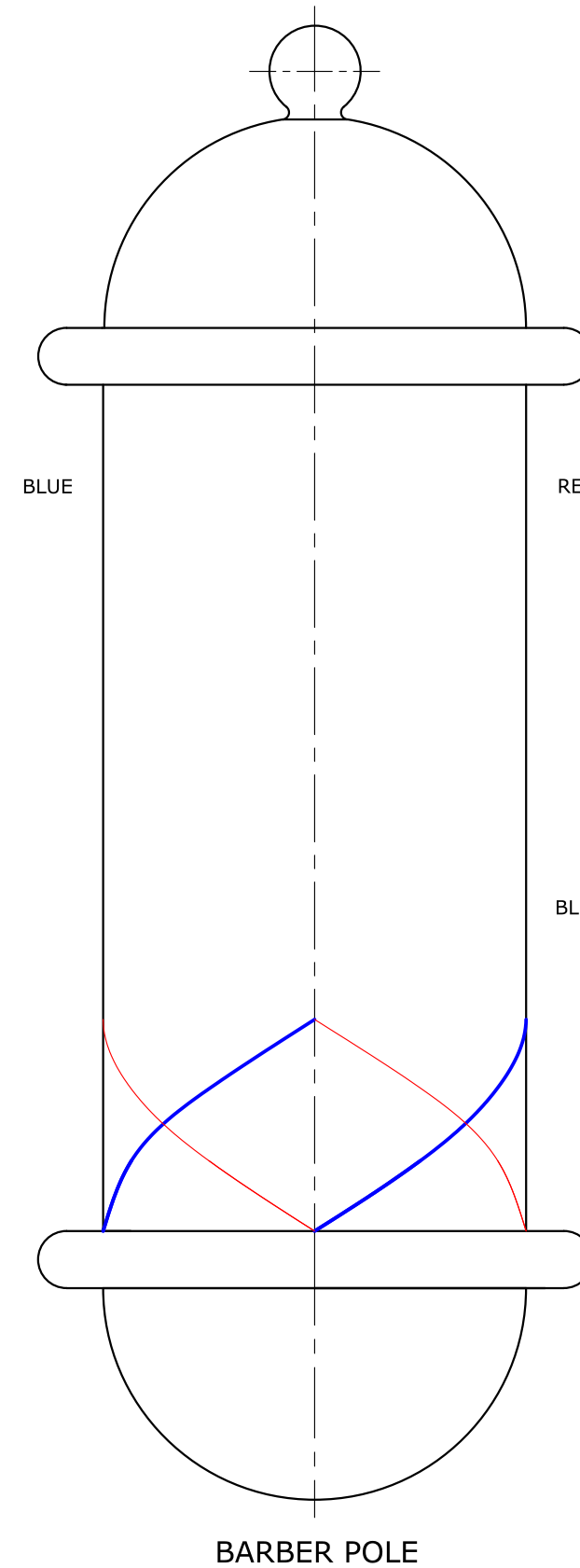
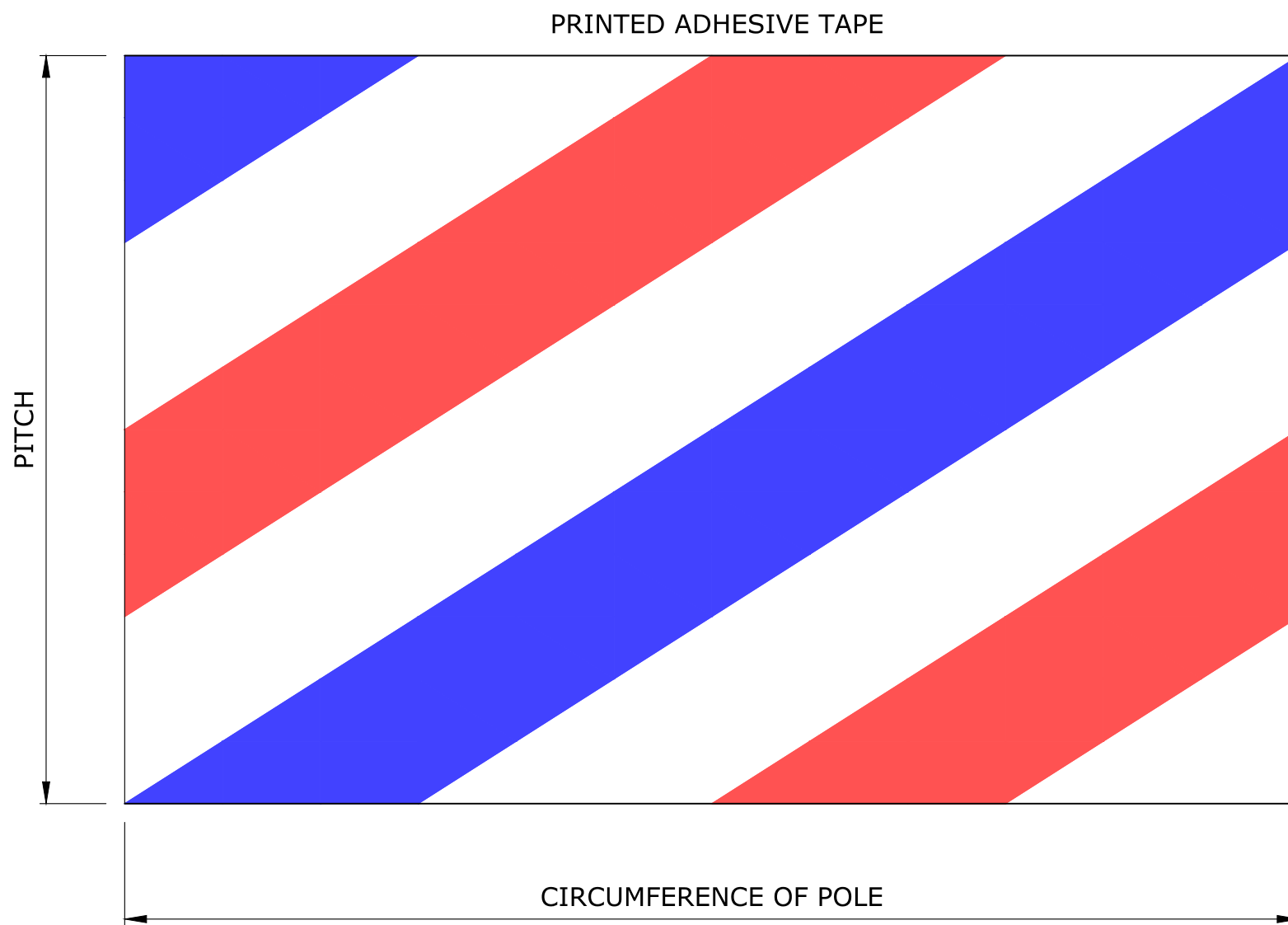

FIGURE A

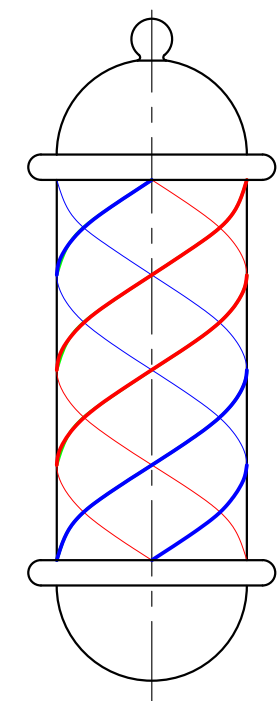

FIGURE B

Question 6.

The upper part of a police academy trophy is shown in the illustrations below. This consists of a metal cylinder intersected by a prismatic shield, producing a hole in the cylinder. The front elevation, plan and an incomplete end elevation are given. You are required to:

- a. complete, by projection, the End elevation showing the resulting curves of intersection; (8)
- b. project the surface development of the cylinder, showing clearly the hole resulting from the intersection with the shield. (10)

Note: Place the joint line along J-J.

(Total: 18 marks)

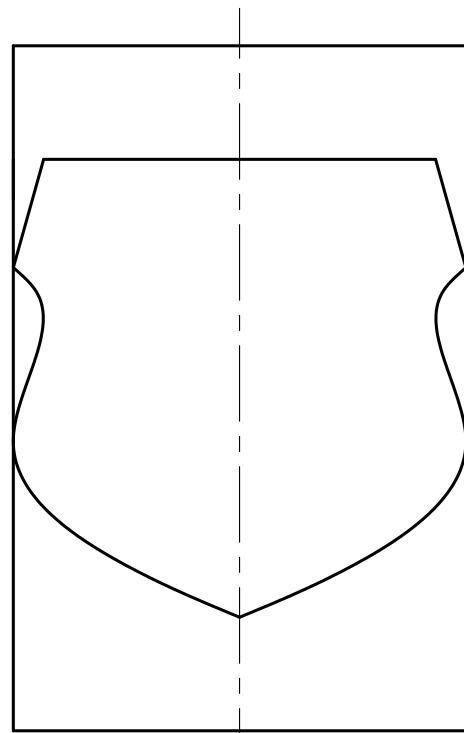

FRONT ELEVATION

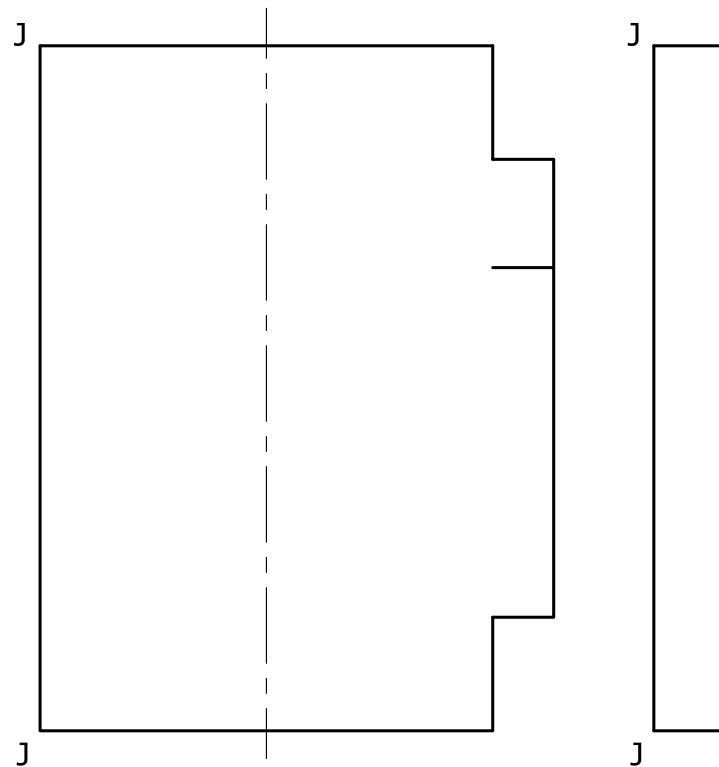

END ELEVATION

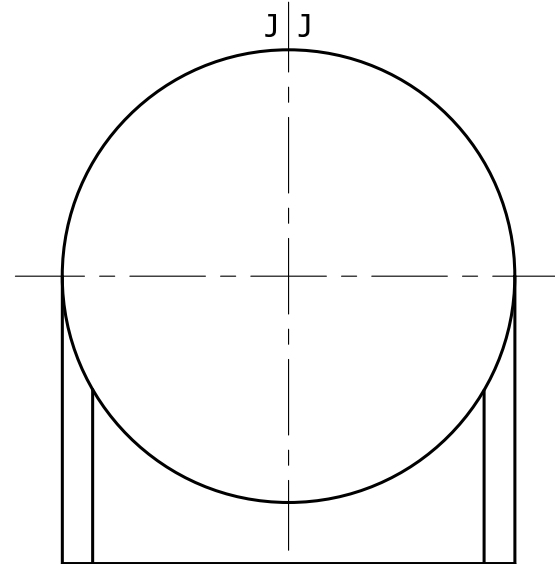

PLAN

SURFACE DEVELOPMENT OF THE CYLINDER

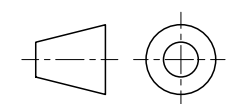
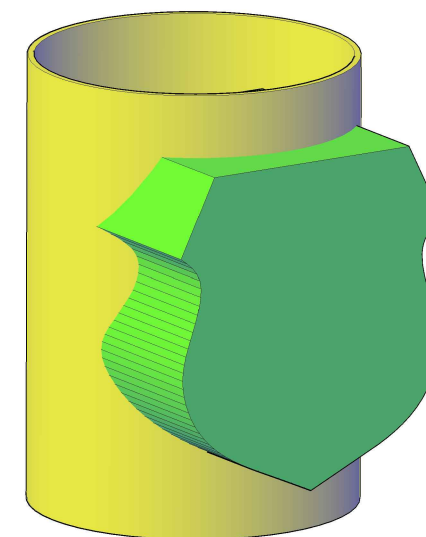

Question 7.

The illustration below shows a variety of large soft playing blocks that can be arranged in different setups. In the case below a tunnel-slide has been formed with blocks A, B, C and D.

A scaled down incomplete front elevation, a plan and an exploded view of the toddler tunnel-slide are given.

- Complete the front elevation. (5)
- On the given $X_1 - Y_1$ line, project an auxiliary elevation of the arrangement as seen from the direction of arrow A. (13)

Notes:

- The steps of block D are 15 mm high.
- Block C is 45 mm high.
- Do not draw hidden details.

(Total: 18 marks)

