

MATRICULATION AND SECONDARY EDUCATION CERTIFICATE EXAMINATIONS BOARD
UNIVERSITY OF MALTA, MSIDA**SECONDARY EDUCATION CERTIFICATE LEVEL****MAY 2013 SESSION**

SUBJECT:	Textiles and Design
PAPER NUMBER:	I
DATE:	4 th May 2013
TIME:	9:00 a.m. to 11:00 a.m.

Answer ALL questions.

1. This top has a beautifully draped peplum that makes a great impression and trims your waist.
- a) The peplum top can be worn over a skirt or a pair of leggings. On the diagrams below, draw a matching skirt for a dress look, **or** a pair of leggings for a more casual outfit. Draw the front and back view of **either** a skirt **or** leggings. (2 marks)

**View A
Front**



**View A
Back**



b) i) Design a different peplum for the top shown below. (2 marks)

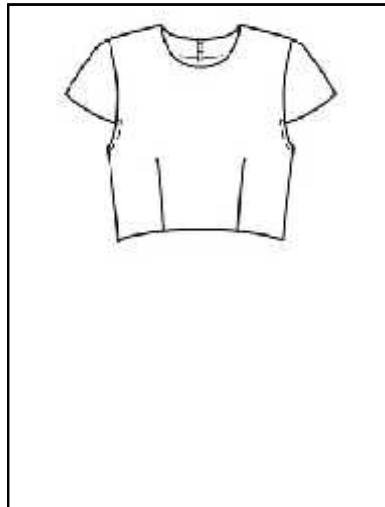

ii) For whom would this new top be suitable? (1 mark)

iii) Give a reason for your choice. (2 marks)

c) These are the pattern pieces of the top in b(i).

i) Complete the pattern layout using all the pattern pieces given. *The peplum layout has been done to help you.*

Pattern Pieces

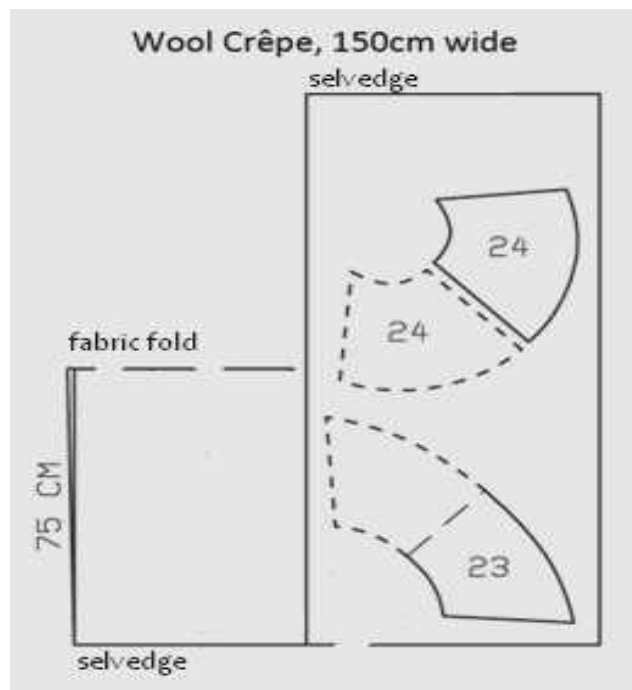
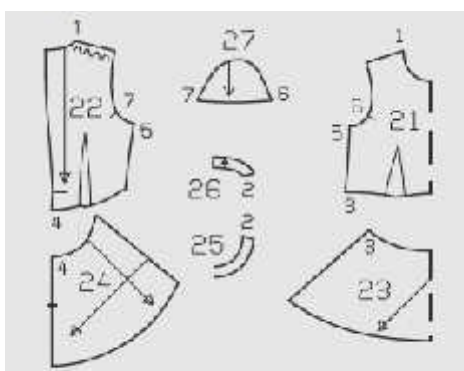

(3 marks)

d) The top shall be made from wool crêpe.

i) Wool Crêpe frays easily. Zig-zag stitch can be used to stop the fabric from fraying. However, there are other stitches that can neaten the fabric better.

- Suggest a finish for the side seam that is more suitable for wool crêpe than zig-zag.

_____ (1 mark)

- Draw the seam finish.

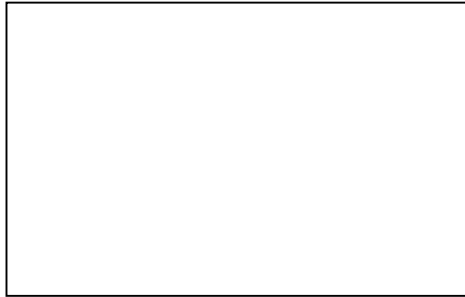

(1 mark)

e) The peplum is fitted at the waist with darts.

i) Write **FOUR** short steps for stitching the darts correctly and draw diagrams showing how to work the waist darts.

1) _____

2) _____



3) _____

4) _____

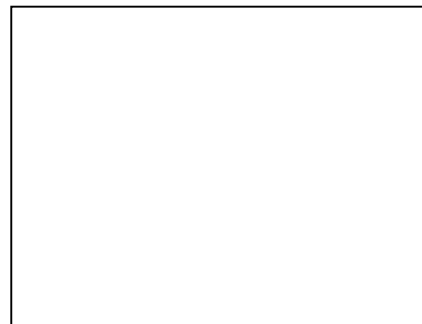

(4, 2 marks)

ii) Vertical darts are pressed towards the _____ while horizontal darts are pressed _____.

(2 marks)

f) Darts are a method of disposing of fullness.

i) Name **ONE** other method of disposing of fullness.

_____ (1 mark)

ii) Where else on a garment can this method be used? Draw a diagram to support your answer.



(1, 1 mark)

g) The peplum has a circular hem.

i) Using the diagram to help you, explain how to turn up and stitch a circular hem.

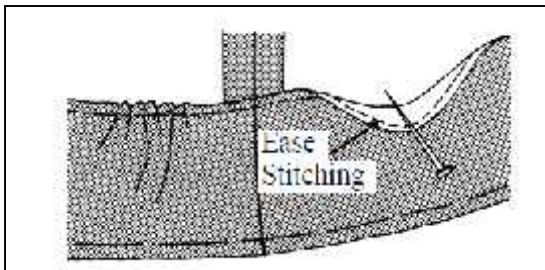

- 1) _____
- _____
- 2) _____
- _____
- 3) _____
- _____

(3 marks)

ii) What is a hem marker useful for?



(1 mark)

h) View B has a fabric variation which creates an interesting effect. The fabric is spotted cotton.

View B



i) On the figure given on the right, draw another variation of the top **without a peplum**, using a different fabric design suitable for a slim lady. (1 mark)

ii) Name the fabric chosen. _____ (1 mark)

iii) List **TWO** reasons why the new fabric design would suit a slim lady.

- (1) _____
- _____
- (2) _____
- _____ (2, 2 marks)

iv) On the same figure, draw a pair of trousers to go with your new top. (1 mark)

- v) List the fashion features of this new outfit.
- _____
 - _____
 - _____ (3 marks)

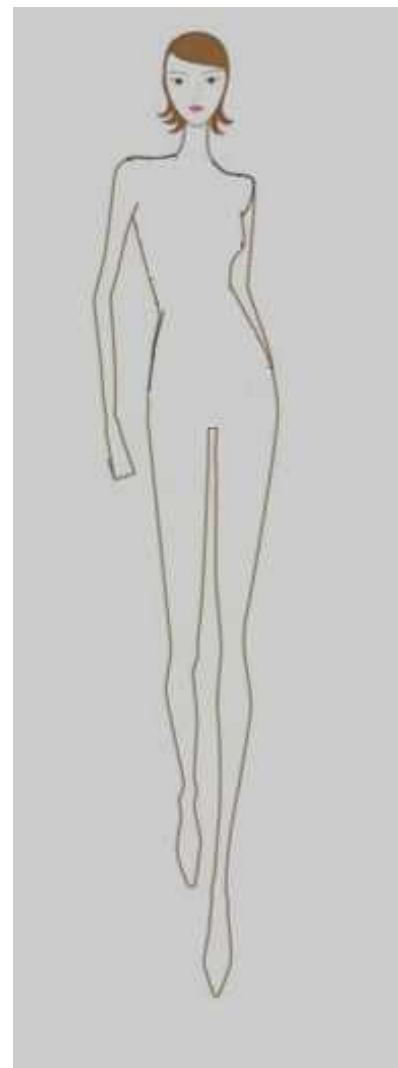

2a. The diagrams below show how to attach a centred zip.
Explain, with the help of the diagrams, how to attach a centred zip to a garment.

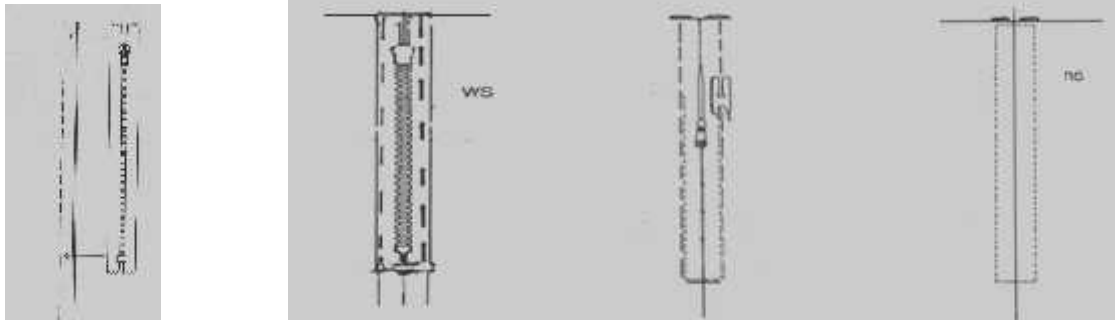

i) _____

ii) _____

iii) _____

iv) _____

_____ (4 marks)

b) i) Name **TWO** places in a garment, where a centred zip **should** be used.

_____ (1 mark)

ii) Explain why a centred zip is the ideal choice for the two places mentioned above, in (bi).

• _____

• _____

_____ (2 marks)

3) The neckline of this top is neatened with a shaped facing.
a) With the help of diagrams, explain how to attach the facing to the top.



i) Place right side of facing with right side of top.

ii) _____

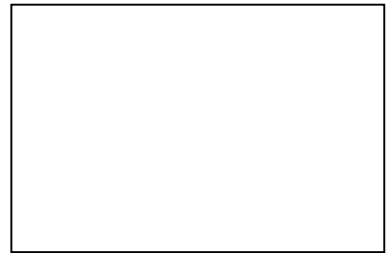

iii) _____



iv) _____



v) _____

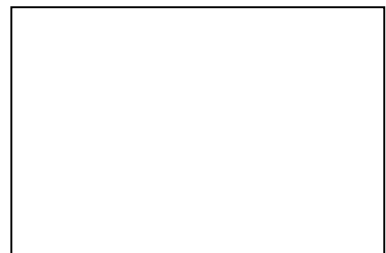

(8 marks)

Please turn the page.

b) Another way of neatening the neckline is to use a crossway strip cut from the same fabric.

i) Using the diagrams to guide you, explain how to cut and join crossway strips.

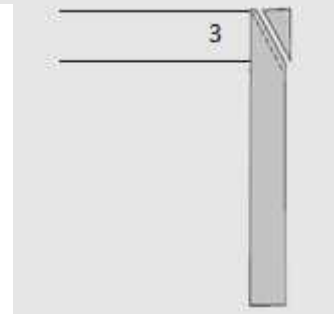
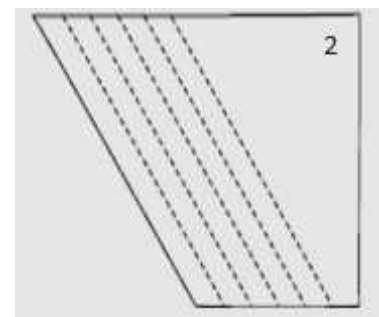
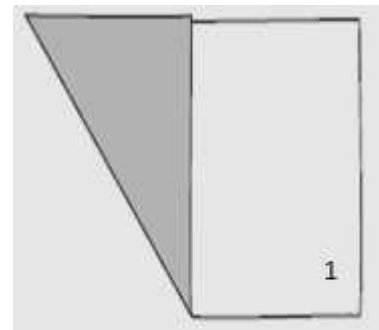

(3 marks)

c) Name **TWO** other areas of a garment, where crossway strips may be used.

i) _____ ii) _____ (1 mark)

4. The diagram shows a pair of shorts.

a) List **THREE** measurements needed to make this pair of shorts.

- i) _____
- ii) _____
- iii) _____



(1½ marks)

b) The shorts shown below is made from lightweight denim. Explain how you would transfer the pattern markings using the tools in the diagram.

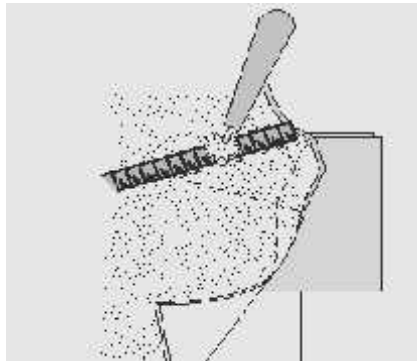

i) _____

ii) _____

iii) _____ (3 marks)

c) Name **ONE** other method of transferring pattern markings.

_____ (½ mark)

d) Give **ONE** reason why pattern markings are useful.

_____ (2 marks)

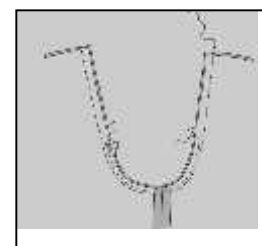

e) After joining the centre back and centre front seam, the under leg seam needs to be joined. Explain how to join this seam as shown in the diagram.

_____ (3 marks)

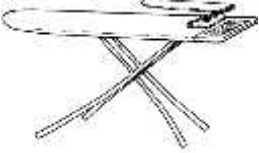

Please turn the page.

f) Proper pressing and ironing during sewing the shorts will give a professional finish.
Name and explain the usefulness of these pressing tools.

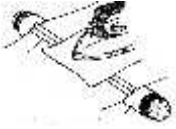
Equipment	Name	Use
	<hr/> <hr/>	<hr/> <hr/>
	<hr/>	<hr/> <hr/>
	<hr/>	<hr/> <hr/>

(1½ marks, 1½ marks)

g) Name the type of pocket on this pair of shorts.

Name of Pocket: _____ (1 mark)



h) Using the pictures to help you, explain how to make up this pocket.

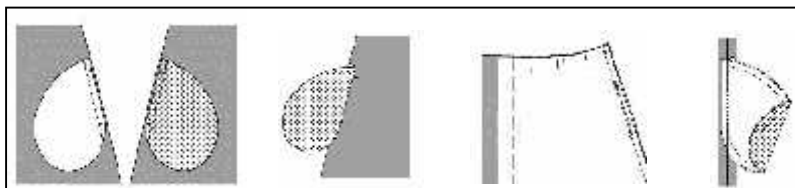

(6 marks)

i) In the box provided draw another pair of shorts with a different pocket and fastened differently from the diagram of the shorts given in question 4(g). (2 marks)

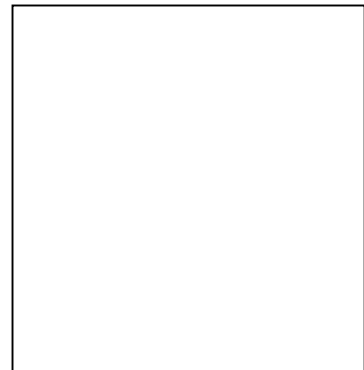

• Name of pocket: _____ (1 mark)

• Name of fastening: _____ (1 mark)

• Draw the fastening. (1 mark)



5) The shorts in question 4, shall be sewn for an eight year old child.



a) Describe how to make up an elasticated waistband/facing as shown in the picture.

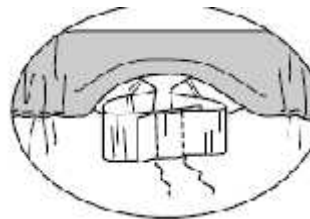
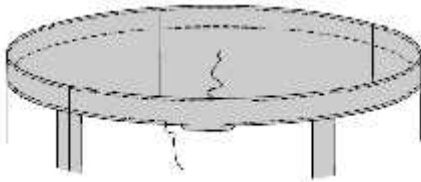

(5 marks)

b) Give **TWO** reasons why an elasticated waistband is more suitable for the child than a fitted waistband.

i) _____

ii) _____

(2, 2 marks)

6) Denim garments can be easily recycled by making them into other items.

a) Draw a small item which you can create out of a pair of old jeans in the box provided below.

b) On the same diagram, draw a motif which can be embroidered on your new item.



(2, 2 marks)

c) Explain, using diagrams, how to make up the item.



(6 marks)

MATRICULATION AND SECONDARY EDUCATION CERTIFICATE EXAMINATIONS BOARD
UNIVERSITY OF MALTA, MSIDA

SECONDARY EDUCATION CERTIFICATE LEVEL

MAY 2013 SESSION

SUBJECT: **Textiles and Design**
 PAPER NUMBER: **IIA**
 DATE: **6th May 2013**
 TIME: **9:00 a.m. to 11:00 a.m.**

Section A: Answer ALL questions

1. There are various models of sewing machines on the market.

a) Describe the different features of the following sewing machines.

Feature	Description
Fully automatic	
Semi-automatic	
Flat bed	
Free arm	

(4 marks)



b) Three friends wish to purchase a sewing machine. They all have different requirements and have asked for your advice. Describe which sewing machine you would advise for each of the following:

	Requirements	Description of the ideal sewing machine recommended.
1	<i>“I sew mostly simple garments for myself, such as skirts and tops. I also sew curtains, do alterations and some mending.”</i>	
2	<i>“I sew straightforward dressmaking in a variety of fabrics, but I like to sew children’s clothes for my young girls.”</i>	
3	<i>“I sew super top-quality garments for myself and family with an individual touch, stylish accessories for the home and I wish to tackle all fabrics successfully.”</i>	

(3 marks)

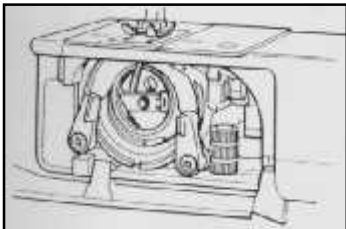
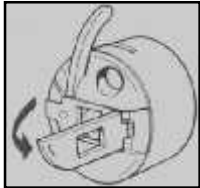
c) Explain the sequence of how to replace a bobbin case and fit it back into the sewing machine. The diagrams below have been given to help you.

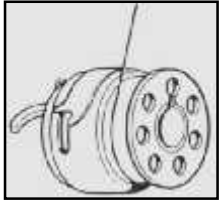
Parts of the bobbin and bobbin case	Explanation
	<hr/> <hr/> <hr/>
	<hr/> <hr/> <hr/>

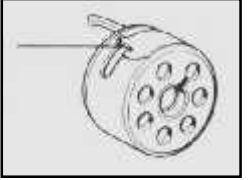
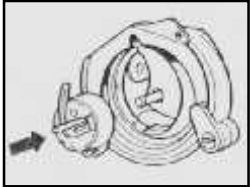

	<hr/> <hr/> <hr/>
	<hr/> <hr/> <hr/>
	<hr/> <hr/> <hr/>
	<hr/> <hr/> <hr/>
	<hr/> <hr/> <hr/>

(7 marks)

d) State the main function of an overlock machine.

(1 mark)

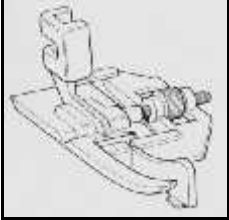
e) Name these **TWO** sewing machine attachments and state their function.

Sewing machine attachment	Name	Function
	<hr/>	
	<hr/>	

(½, ½, 1, 1 mark)

2. Irons differ in a number of ways. Manufacturers are offering various features, like digital displays, retractable cords, and drip-free steaming amongst others.



a) Explain the following features found on steam irons.

i. Auto shut-off;

_____ (1 mark)

ii. Burst-of-steam button;

_____ (1 mark)

iii. Convenient controls;

_____ (1 mark)

iv. Transparent water reservoir;

_____ (1 mark)

v. Retractable cord.

_____ (1 mark)

b) Why is it important to sort garments according to their heat settings when one is about to begin ironing clothes?

(1 mark)

c) Why is spray starch used whilst ironing some garments?

(1 mark)

d) Name **ONE** fabric that requires the use of starch during ironing.

(1 mark)

e) State the difference between ironing and pressing.

(2 marks)

f) What precaution should one take when ironing a fabric with a nap or a pile?

(2 marks)

g) Give **FIVE** safety rules to follow **after** finishing ironing your clothes and preparing to store the steam iron.

- i. _____
- ii. _____
- iii. _____
- iv. _____
- v. _____ (5 marks)

3. Down jackets are suitable for extreme cold weather. The outer layer and lining materials are usually made from 100% polyester.



a) Give **TWO** reasons why polyester is a good choice for these type of jackets.

i. _____

ii. _____

(1½, 1½ marks)

b) The filling of some jackets are made from 50% feathers and 50% down. Give **TWO** advantages of using these materials as filling for these types of jackets.

Advantage 1 _____

Advantage 2 _____

(1, 1 mark)

Section B: Answer ALL questions

4a) Nowadays online shopping has become very popular. A working mother with a young baby decides to use this method to buy clothes for herself and for her family.



i. What is online shopping?

_____ (1 mark)

ii. Online shops are also called _____ (1 mark)

b) State **THREE** advantages and **THREE** disadvantages if a working mother were to buy clothes through online shopping.

Advantages:

i. _____

ii. _____

iii. _____ (3 marks)

Disadvantages:

- i. _____
- ii. _____
- iii. _____ (3 marks)

c) Describe **TWO** other ways of shopping for clothes.

- i. _____

- ii. _____
_____ (2 marks)

d) Describe **TWO** precautions one needs to take when shopping online.

- i. _____
- ii. _____ (2 marks)

e) Which is the best method of payment one should choose?

_____ (1 mark)

f) *Define* misleading advertising.

_____ (2 marks)

g) An online shopper has certain rights and responsibilities. State **ONE** right and **ONE** responsibility as an online consumer.

Right: _____
_____ (1 mark)

Responsibility: _____
_____ (1 mark)

h) A large number of websites encourage consumers to shop online. List **THREE** ways how the young mother can keep within her planned budget when shopping for clothes online.

- i. _____
- ii. _____
- iii. _____ (3 marks)

5. All active sports enthusiasts want to wear comfortable clothing.

a) i. Describe the following properties found in most sportswear.

- Stretch and snap-back:

_____ (1 mark)

- Durability:

_____ (1 mark)

- Chemical resistance:

_____ (1 mark)

ii. Name and describe another popular characteristic found in sportswear.

Name: _____

Description: _____

_____ (1, 1 mark)

b) Describe the correct way of caring for swimwear after using in a chlorinated swimming pool.

_____ (3 marks)

c) Explain how you would conduct an experiment to test and compare **THREE** different fabrics for elasticity.

- i. Name the equipment required.
- ii. Describe the method of conducting this experiment. **Support your answers with a clear and well-labelled diagram.**

Diagram

Equipment required:

(3 marks)



(3 marks)

Method:

(6 marks)

Please turn the page.

6. Eco-fashion encourages consumers to use sustainable materials for clothing.

a) Name **THREE** principles that eco-fashion follows.

i. _____

ii. _____

iii. _____ (3 marks)

b) Identify **THREE** ways how the environment can benefit if consumers follow the principles of eco-fashion.

i. _____

ii. _____

iii. _____ (3 marks)

c) i. Name the **TWO** types of silk fabric that are considered as environment friendly.

Types of Silk: _____

(2 marks)

ii. Name and draw the type of weave that produces a 'silky' appearance.

Name of weave: _____



(2 marks)

d) Describe **TWO** aesthetic properties of silk fabrics and **TWO** performance properties of silk fibres.

Aesthetic properties:

i. _____

ii. _____ (2 marks)

Performance properties:

- i. _____
- ii. _____ (2 marks)

e) Marketing campaigners promote: '*Natural is best*'. Cotton is considered as one of the natural fibres that is **not** environment friendly.

- i. Describe **TWO** factors that make the production of cotton not environmentally friendly.
 - _____
 - _____
- _____ (2 marks)

- ii. Name the **TWO** types of environment friendly cotton.
 - _____
 - _____
- _____ (2 marks)

- iii. Natural dyes have been used throughout history. Name **FOUR** natural dyes that can be used to colour cotton fabrics.
 - _____
 - _____
 - _____
 - _____
- _____ (2 marks)

Blank Page

MATRICULATION AND SECONDARY EDUCATION CERTIFICATE EXAMINATIONS BOARD
UNIVERSITY OF MALTA, MSIDA

SECONDARY EDUCATION CERTIFICATE LEVEL

MAY 2013 SESSION

SUBJECT: **Textiles and Design**
 PAPER NUMBER: **IIB**
 DATE: **6th May 2013**
 TIME: **9:00 a.m. to 11:00 a.m.**

Section A: Answer ALL questions

1. The following are various models of sewing machines on the market:







Flat-bed sewing machine, free-arm sewing machine, semi-auto sewing machine, fully-automatic sewing machine

a) Match each description of the sewing machine model by using a suitable name found in the above box.

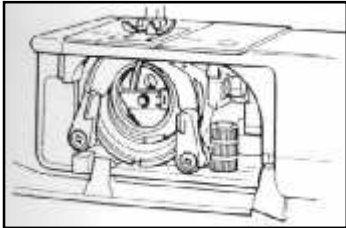
Description	Name of the sewing machine
Quicker and easier to operate. This machine has the pattern cams built into the machine and the operator can select the stitch required by the selector dial	
This is often called sleeve-arm machine. The slim arm under the needle makes sewing collars, cuffs, trousers, armholes, sleeves and children’s clothes easier to sew.	
This will do limited sewing (i.e. straight stitch and zig-zag, thus working a buttonhole) and is at the bottom end of the price range. This is a traditional type to fit into a sewing cabinet and it is often very heavy.	
Usually a reasonably basic zig-zag machine which will provide some extra stitches such as a stretch stitch, blind hemming and maybe limited embroidery patterns. Sometimes it includes four-stage buttonhole.	

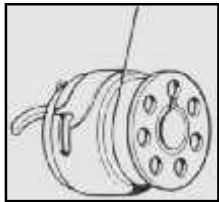
(4 marks)

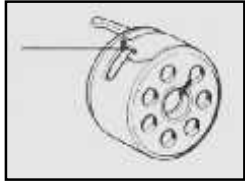
b) Match the diagrams of how to replace a bobbin case and fit it back into the sewing machine. In the empty column, write the correct number of each picture with its correct description.

Parts of the bobbin and bobbin case	Explanation	Correct number
<p>1</p> 	<p>Position the bobbin case filled with the full threaded bobbin back into the shuttle. Release the latch.</p>	
<p>2</p> 	<p>Pull the thread</p>	
<p>3</p> 	<p>Open the spring loaded latch of the bobbin case.</p>	
<p>4</p> 	<p>See that the thread is secure into the tension spring.</p>	
<p>5</p> 	<p>Gripping the spring loaded latch, remove the bobbin case from the shuttle case.</p>	
<p>6</p> 	<p>Insert a full bobbin into the bobbin case</p>	
<p>7</p> 	<p>Raise the sewing machine needle to its highest position. Open the shuttle cover.</p>	<p>1</p>

(6 marks)

c) You have decided to sew a motif on a pocket using a sewing machine. Name the appropriate stitch chosen? Give a reason for your choice.

Name of Stitch: _____ (1 mark)

Reason: _____
_____ (1½ marks)

d) The following flow chart below explains how to turn a corner whilst sewing. Fill in with the words in italics.

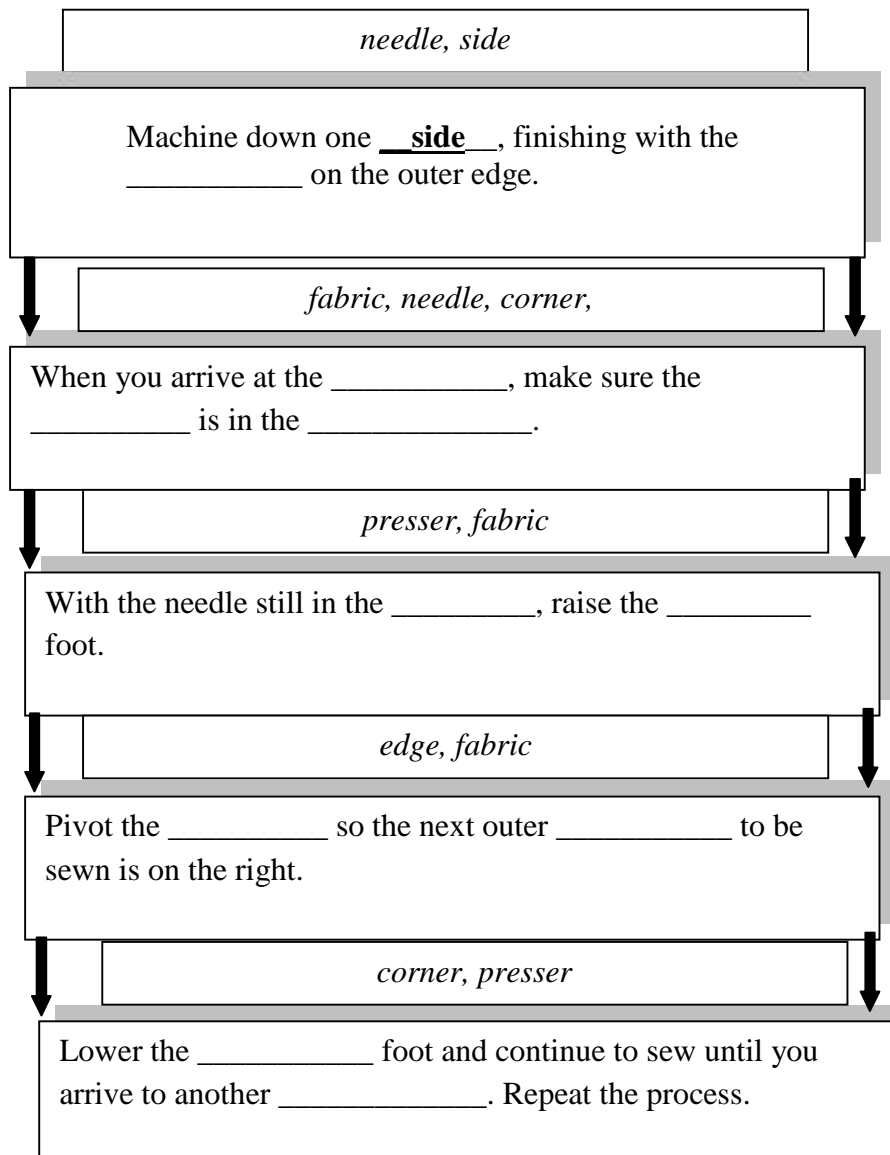

(5 marks)

e) Why is it useful to have an overlock machine in your sewing room?

_____ (1 mark)

f) Why is it important to have a colour or a symbol-coded graphic chart available with the overlock machine?



_____ (2 marks)

2. There are several modern steam irons on the market. Many models have different features which make ironing easy.



a) Give an **ADVANTAGE** of having each of the following features.

i. Some irons have an **auto shut-off** feature. This feature will turn-off the power if the iron is left motionless, laid flat or propped up. Why is this feature considered important?

ADVANTAGE: _____ (1½ marks)

ii. **Convenient controls** may include the fabric guide, with a list of settings for common fabrics, a temperature control and an indicator light. Why do you think it is important that an iron has these convenient controls?

ADVANTAGE: _____ (1½ marks)

iii. **Transparent water reservoir** is a compartment that makes it easy to see the water level in a steam iron. Why is it necessary to have a transparent water reservoir?

ADVANTAGE: _____ (1½ marks)

b) Why is it important to sort garments according to their heat settings when one is about to begin ironing clothes?

_____ (2 marks)

c) Why is spray starch used whilst ironing certain garments?

_____ (1 mark)

d) Name **ONE** fabric that requires the use of starch during ironing.

_____ (1 mark)

e) A sleeve board and an ironing board are two pressing equipment that are essential in a sewing room. Name **TWO** other pressing equipment needed and state their use. *Do not include an iron as one of the pressing equipment.*

- Name of pressing tool I: _____
- Use of pressing tool I: _____
- Name of pressing tool II: _____
- Use of pressing tool II: _____ (1½, 1½ marks)

3. This care label is suitable for a garment made from 100 % polyester.

a) Give the name of each of the care label symbol shown on the label below.

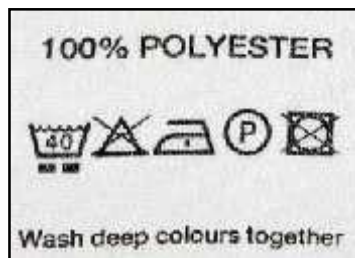

- i) Symbol No.1: _____
- ii) Symbol No.2: _____
- iii) Symbol No. 3: _____
- iv) Symbol No. 4: _____
- v) Symbol No. 5: _____ (5 marks)

b) Polyester is a very popular fabric. Give **THREE** properties of polyester.

- i. _____
- ii. _____
- iii. _____ (3 marks)

Section B: Answer all questions

4a) A working mother with a young child decides to use online shopping to buy clothes for herself and for her family.



- i. What is online shopping?

_____ (2 marks)
- ii. Online shops are also called E-_____ (1 mark)

b) Give **THREE** advantages and **THREE** disadvantages of shopping for clothes online, for this young mother.

Advantages:

- i. _____
- ii. _____
- iii. _____ (3 marks)

Disadvantages:

- i. _____
- ii. _____
- iii. _____ (3 marks)

c) Describe **TWO** other methods of shopping for clothes.

- i. _____

ii. _____
_____ (1½, 1½ marks)

d) Name **TWO** precautions one needs to take when shopping online.

i. _____
ii. _____ (2 marks)

e) Which is the best method of payment when shopping online?

_____ (1½ marks)

f) Why is it important **NOT** to send personal or financial information by email?

_____ (1½ marks)

g) An online shopper has certain rights and responsibilities. Give **ONE** right and **ONE** responsibility one has as an online consumer.

Right: _____
_____ (1½ marks)

Responsibility: _____
_____ (1½ marks)

5a) All active sports enthusiasts want to wear comfortable clothing.

i. Describe the following properties found in most sportswear.

• *Durability*: _____
_____ (1½ marks)

• *Lightweight*: _____
_____ (1½ marks)

Please turn the page.

ii. Describe the correct way of caring for swimwear after using it in a chlorinated swimming pool.

(3 marks)

b) The following diagram shows the equipment required to test and compare **THREE** fabrics for elasticity.

i. **LABEL** the diagram with the given words: *bulldog clips, fabric, retort stand, steel rod, clamp and pocket for weights*.

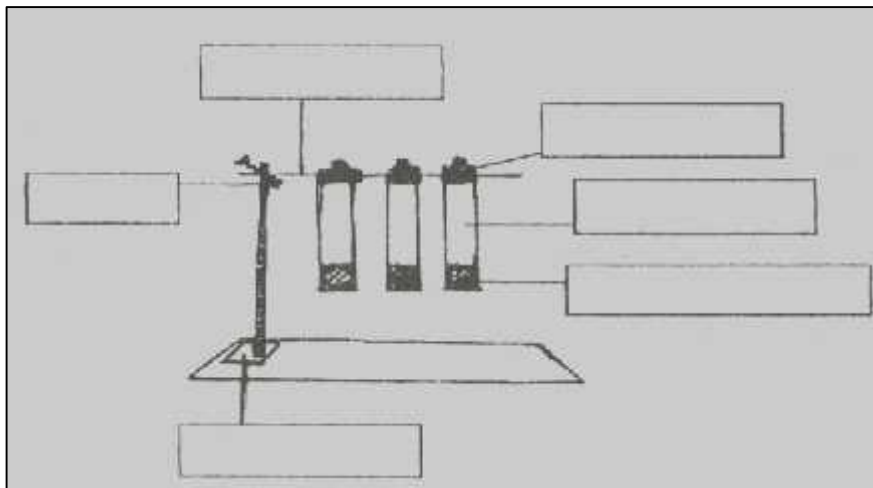

(3 marks)

ii. **DESCRIBE** how this experiment is carried out.

Method: _____

(5 marks)

c) i. What type of machine stitching should you use when sewing stretch fabric? Give a reason for your choice.

- Machine stitch for stretchy fabric: _____ (1 mark)

- Reason: _____
 _____ (2 marks)

ii. **Wool stretch** is a new fabric blend that combines the best qualities of Lycra and wool.

- Name **TWO** garments that can be made from **wool stretch** fabric.
 _____ (1 mark)

- Why is it recommended to dry clean a garment made from **wool stretch** fabric?

 _____ (2 marks)

6. Eco-fashion encourages consumers to use sustainable materials to make clothes.

a) Name **TWO** principles that eco-fashion follows.

Example: Stylish garments can be made from second-hand clothes

- i. _____
- ii. _____ (2 marks)

b) Name **THREE** ways how the environment can benefit if consumers follow the principles of eco-fashion.

- i. _____
- ii. _____
- iii. _____ (3 marks)

c) Some silk is described as being environmental friendly because it allows the silkworms to come out from their cocoons to live out their full life cycle. Choose the **TWO** types of silk fabrics that are considered to be environment friendly.

i. Types of silk that are environment friendly (Underline **TWO**)

Dupioni	Noil	Wild
---------	------	------

(2 marks)

ii. Name and draw the type of weave that produces a 'silky' appearance.

Name of weave: _____

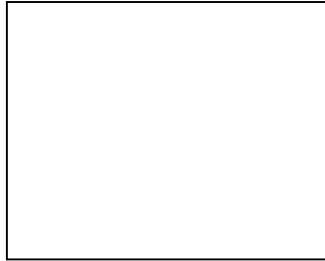

(2 marks)

d) Give **THREE** properties of silk fabrics.

i. _____

ii. _____

iii. _____ (3 marks)

e) Why is silk an expensive fabric?

_____ (1mark)

f) Cotton is considered as one of the natural fibres that is **NOT** environment friendly.

i. Give **ONE** reason why cotton is not considered as environment friendly.

Reason: _____

_____ (2 marks)

ii. Name **TWO** types of environment friendly cotton.

• _____

• _____

(2 marks)

iii. Name **THREE** natural dyes that can be used to colour cotton fabrics.

• _____

• _____

• _____ (3 marks)

Blank Page

Blank Page