

MATRICULATION AND SECONDARY EDUCATION CERTIFICATE EXAMINATIONS BOARD
UNIVERSITY OF MALTA, MSIDA

SECONDARY EDUCATION CERTIFICATE LEVEL

MAY 2015 SESSION

SUBJECT: **Textiles and Design**
 PAPER NUMBER: I
 DATE: 25th May 2015
 TIME: 9:00 a.m. to 11:00 a.m.

Answer ALL questions.

1. A fully-lined fitted jacket/ blazer is fashionable all the year round. This is a versatile jacket and can be worn for various occasions and functions.

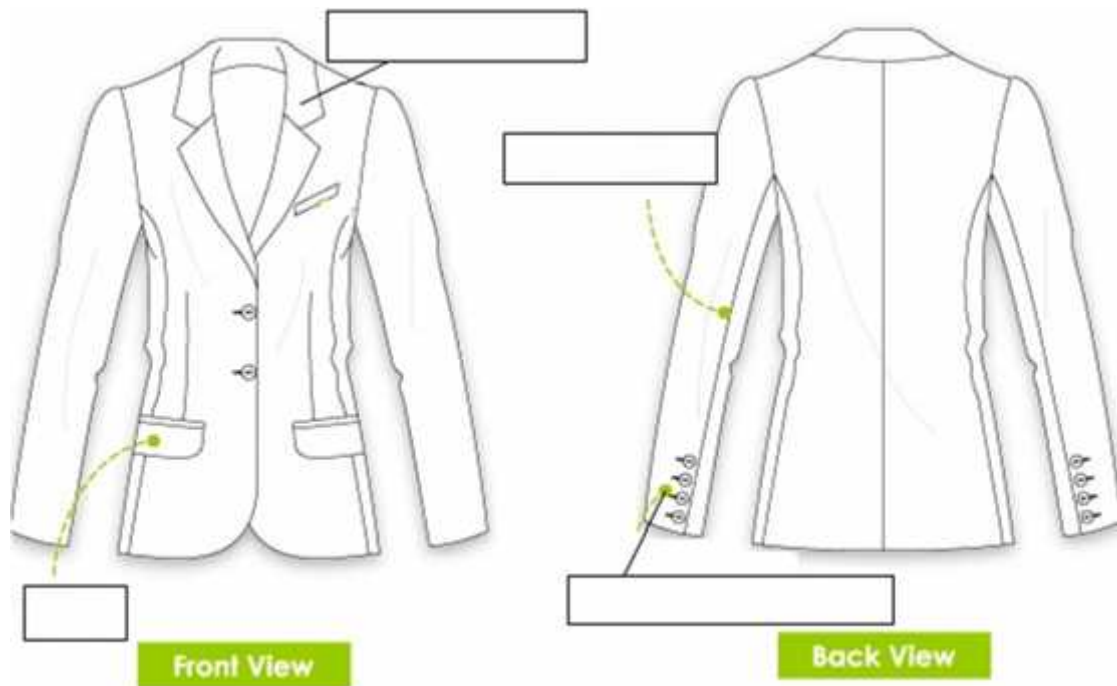

a) On the diagram provided, name the **MARKED** style features. (½, ½, ½, ½ marks)

b) Suggest a suitable fabric and colour for this jacket and give a reason for both choices.

i. Name of fabric: _____ (½ mark)

ii. Reason: _____

_____ (2 marks)

DO NOT WRITE ABOVE THIS LINE

iii. Colour: _____ (½ mark)

iv. Reason: _____
_____ (2 marks)

c) Suggest a suitable fabric to line this jacket.

_____ (½ mark)

i. Explain why it is important to line a garment.

_____ (2 marks)

d) Define interfacing. State its function.

i. _____

_____ (2 marks)

ii. _____

_____ (2 marks)

iii. Name **two** different interfacings that one can find on the market.

- _____
- _____

(½, ½ mark)

e) Identify **three** parts from the jacket that need to be interfaced.

- i. _____
- ii. _____
- iii. _____

(1 ½ marks)

DO NOT WRITE ABOVE THIS LINE

f) State **two** important factors that should be considered when choosing an interfacing?

i. _____

ii. _____

(2 marks)

g) Put, in numerical order, the method of how one would apply an interfacing to a specific area in a garment. **Number 1 has been done for you.** (3 marks)

When the fabric has cooled down, the fusing process will be complete. Then pin the pattern back on the fabric and transfer the pattern markings as required.	
Place the chosen interfacing sticky side down on the fabric.	
Place a steam iron, on a steam setting, on top of the pressing cloth.	
Place fabric on pressing surface, wrong side up, making sure it is straight and not wrinkled.	1
Cover with a dry pressing cloth and spray the cloth with a fine mist of water.	
Leave the iron in place for at least 10 seconds before moving it to the next area of fabric.	
Check to see if the interfacing is fused to the fabric by rolling the fabric. If the interfacing is still loose in places, repeat the pressing process.	

h) In the space provided, draw and name another style of pocket which could be used on the jacket on page 1.



(1 mark)

Name of pocket. _____

(½ mark)

DO NOT WRITE ABOVE THIS LINE

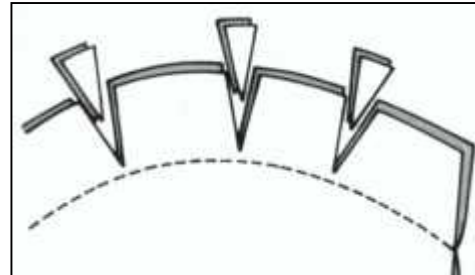
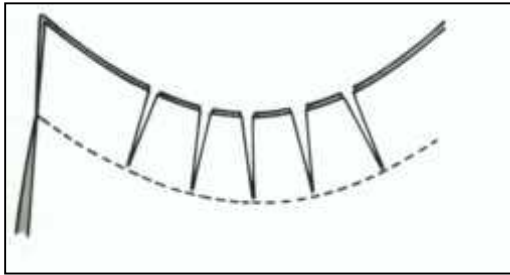

i) Depending on the type of curve, the above seams need to be, either _____ or _____.
(½, ½ mark)

j) Name the seam on the jacket that needs one of these methods.

Name of seam. _____ (1 mark)

k) On the fashion template given below, draw **TWO** different trousers that could be worn with the jacket in question 1.

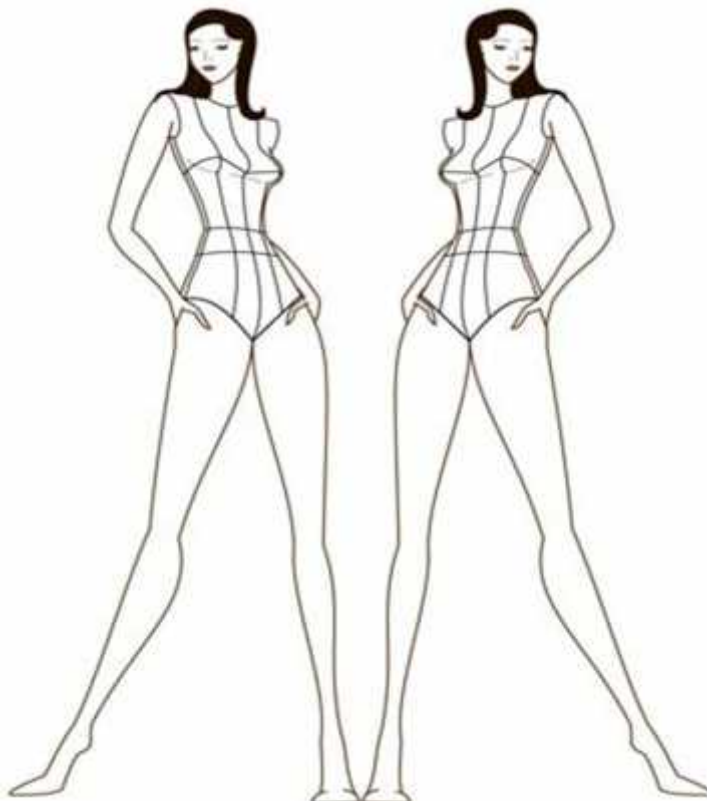

(2 marks)

l) In one of your drawing, include **THREE** fashion features and label each one of them.
(3 marks)

DO NOT WRITE ABOVE THIS LINE

2. The figures below show four common figure types.

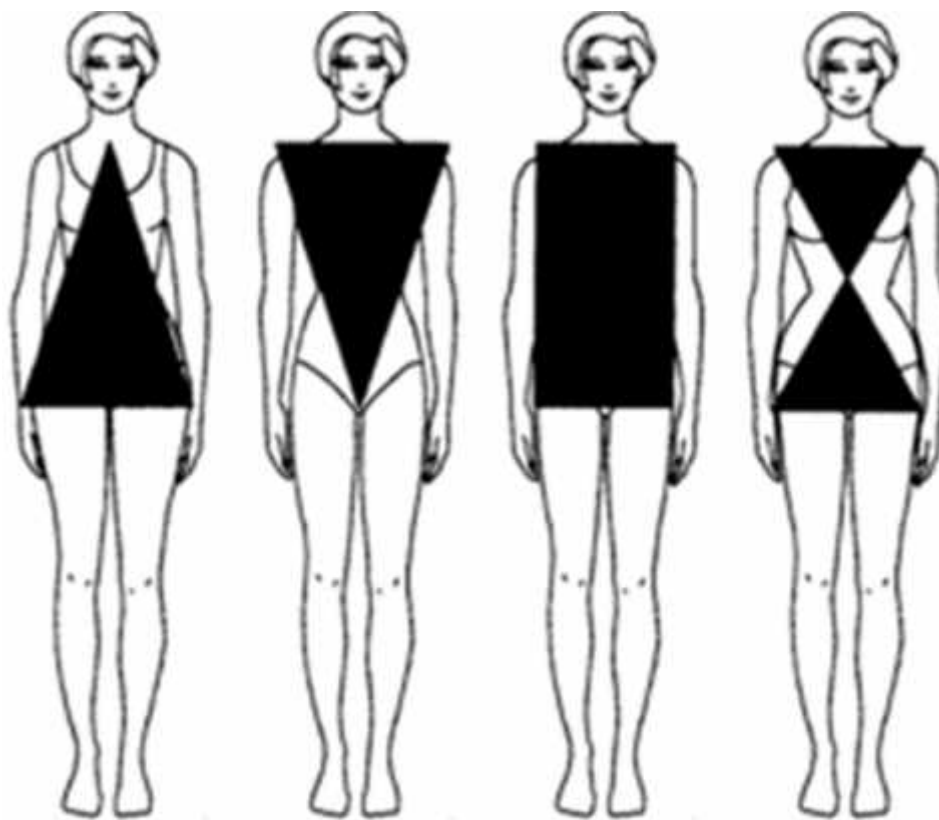

Triangle shape	Inverted triangle shape	Rectangle shape	Hourglass shape
-------------------	-------------------------------	--------------------	--------------------

Describe briefly the characteristics of each figure type. Suggest a suitable outfit for each figure type. ***The first one has been done for you.***

- Triangle shape:
This is a common figure type for women and features hips and thighs which are broader (wider) in comparison to the rest of the body. Being bottom heavy makes the figure look shorter.

Ideal outfit for a triangle shape figure:

It is important for this figure type to draw the eye to the upper part of the body, and balance the figure with decorative features. Therefore a light bright coloured blouse or top and dark or dull skirt would enhance this figure type.

DO NOT WRITE ABOVE THIS LINE

- Inverted triangle shape:

(2 marks)

Ideal outfit for an inverted triangle shape figure:

(2 marks)

- Rectangle shape:

(2 marks)

Ideal outfit for a rectangle shape figure:

(2 marks)

- Hourglass shape:

(2 marks)

Ideal outfit for an hourglass shape figure:

(2 marks)

DO NOT WRITE ABOVE THIS LINE

3. Children's clothing has come a long way in the past few years.

a) On the diagram below, sketch a summer outfit suitable for a **three-year-old** child.

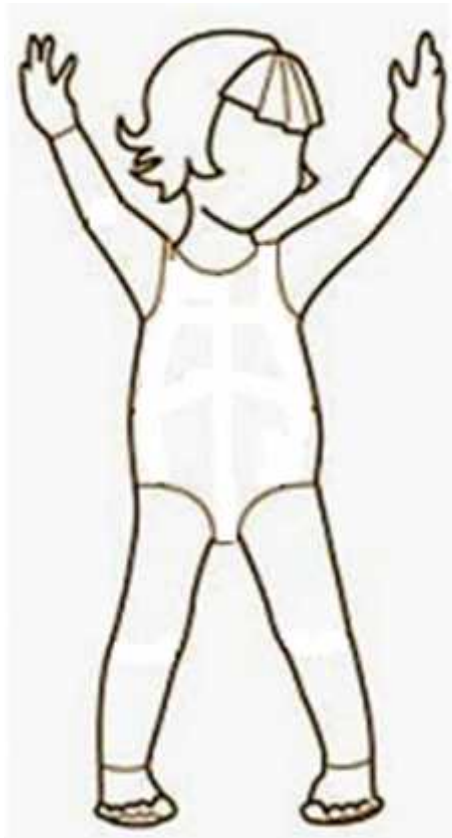

(2 marks)

b) Give a reason to justify the style chosen. Suggest a suitable fabric for your design and give a reason for your choice.

• Reasons for style chosen: _____

• Suitable Fabric: _____

• Reason for choice of fabric: _____

(2, ½, 2 marks)

DO NOT WRITE ABOVE THIS LINE

c) Give **ONE** example how a child’s outfit can make allowance for:

- Growing needs;

(1 mark)

- Freedom of movement.

(1 mark)

d) Identify **ONE** safety precaution that needs to be taken into consideration when choosing fastenings for this child’s outfit.

- Safety precaution.

(1 mark)

e) Pleats are one method of disposing of fullness. Suggest **TWO** other methods of disposing of fullness and illustrate your answers in the boxes provided.

Method _____ (1, 2 marks)

Method _____ (1, 2 marks)

DO NOT WRITE ABOVE THIS LINE

f) Zippers have been around for a long time. These are durable, popular and convenient. Nowadays, there are various types on the market. Name **THREE** types of zippers that are commonly used.

- Name of zipper _____ (1 mark)
- Name of zipper _____ (1 mark)
- Name of zipper _____ (1 mark)

g) One of the zippers has been drawn for you. Name **all** the parts marked with an arrow.

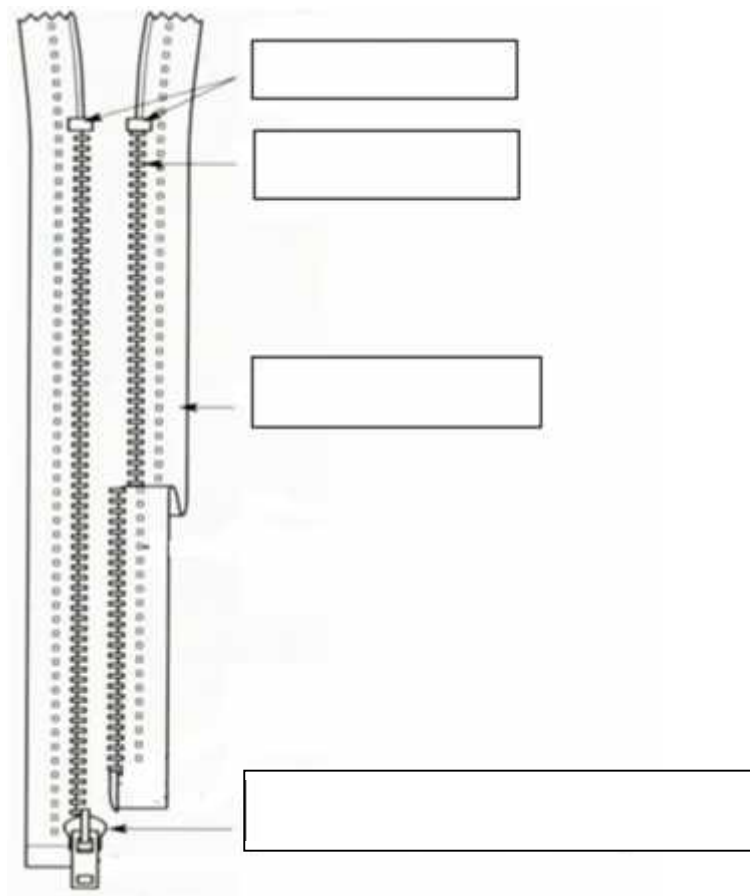

(2 marks)

DO NOT WRITE ABOVE THIS LINE

4. Plaids and checks have remained popular over the years. It is essential that seams on checks and plaids meet on a garment.

a) Name **THREE** seams that must be matched when sewing a checked garment.

- _____
- _____
- _____

(3 marks)



b) Describe **TWO** important factors which need to be kept in mind when buying checked or plaid fabrics.

- _____

(2 marks)

- _____

(2 marks)

DO NOT WRITE ABOVE THIS LINE

5. The diagrams on the right show the front and back view of a plain skirt finished with a facing at the waistline.

With the help of the following diagrams, describe the process to follow when preparing and attaching the facing to the skirt. **Numbers 1 and 8 have been done for you.**

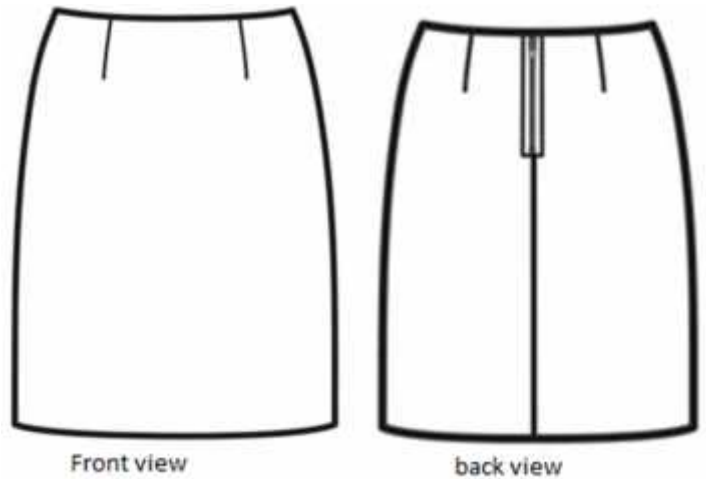

1		<i>Insert zipper</i>
2		
3		
4		
5		

DO NOT WRITE ABOVE THIS LINE

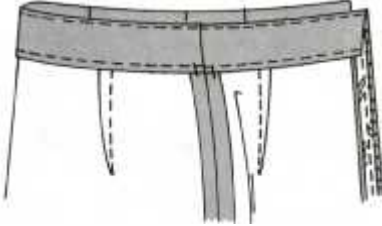
6		
7		
8		<p><i>Sew hook and eye to opening above zipper and press the finished facing.</i></p>

(6 marks)

6. The picture below gives the information found on the front of a pattern envelope.

a) Name the parts that are marked with an arrow.



(4 marks)

DO NOT WRITE ABOVE THIS LINE

b) Identify **FIVE** important pieces of information found on the back on the pattern envelope.

- _____
- _____
- _____
- _____
- _____

1315

5 PIECES/PIEZAS

Métrages et Instructions de couture en Français à l'intérieur de l'enveloppe.

MISSES' PULLOVER BLOUSE WITH SLEEVE AND TRIM VARIATIONS

Fabrics: Silky lightweight to medium weight woven fabrics with drape such as: Challis, Charmeuse, Crepe De Chine, Double Georgette, Lightweight Linen Types, Silky Types. Extra fabric needed to match plaids, stripes or one-way design fabrics.

Notions: Thread. **A:** Six 1/2" buttons. **B:** Six snaps. Look for Simplicity Trims.

BODY MEASUREMENTS (For Sizing Help Visit www.simplicity.com/sizehelp)

Bust	30 1/2	31 1/2	32 1/2	34	36	38	40	42	44	In
Waist	23	24	25	26 1/2	28	30	32	34	37	"
Hip-9" below waist	32 1/2	33 1/2	34 1/2	36	38	40	42	44	46	"
Back-neck to waist	15 1/2	15 1/4	16	16 1/4	16 1/2	16 3/4	17	17 1/4	17 1/2	"

Pattern Size 6 8 10 12 14 16 18 20 22

Sizes-European 32 34 36 38 40 42 44 46 48

A,B Blouse

45***	2 1/4	2 1/2	2 3/4	2 3/4	2 3/4	2 3/4	3	3	3 1/2	Yd
60***	1 1/2	1 1/2	1 1/2	1 1/2	1 1/2	2 1/2	2 1/2	2 1/2	2 1/2	"

Interfacing- 1/2 yd. of 20" to 25" lightweight fusible, such as Pellon®

B Novelty Embroidered Trim- 1/4 yd. of 2" wide

C,D Blouse

45***	2 1/4	2 1/2	2 3/4	2 3/4	2 3/4	2 3/4	3	3	3 1/2	Yd
60***	1 1/2	1 1/2	1 1/2	1 1/2	1 1/2	2 1/2	2 1/2	2 1/2	2 1/2	"

D Lace- 1 1/2 yd. of 1 1/2" wide

E Blouse

45***	1 1/2	1 1/2	2	2	2 1/2	2 1/2	2 1/2	2 1/2	2 1/2	Yd
60***	1 1/2	1 1/2	1 1/2	1 1/2	1 1/2	1 1/2	1 1/2	1 1/2	1 1/2	"

F Blouse

45***	1 1/2	1 1/2	1 1/2	1 1/2	1 1/2	1 1/2	1 1/2	1 1/2	1 1/2	Yd
60***	1 1/2	1 1/2	1 1/2	1 1/2	1 1/2	1 1/2	1 1/2	1 1/2	1 1/2	"

Contrast Sleeves

45***	1/2	1/2	1/2	1/2	1/2	1/2	1/2	1/2	1/2	Yd
60***	1/2	1/2	1/2	1/2	1/2	1/2	1/2	1/2	1/2	"

FINISHED GARMENT MEASUREMENTS (Includes Design and Wearing EASE)

A,B,C,D,E,F Bust 36 1/2 37 1/2 38 1/2 40 42 44 46 48 50 In

Finished back length from base of neck:

A,B,C,D,E,F 24 1/2 24 1/2 25 25 1/2 25 1/2 25 1/2 26 26 1/2 26 1/2 In

*without nap **with nap ***with or without nap



A,B



C,D



E,F

(5 marks)



7. The following steps of preparing and attaching the collar are not in their proper order.

a) Number the steps correctly.

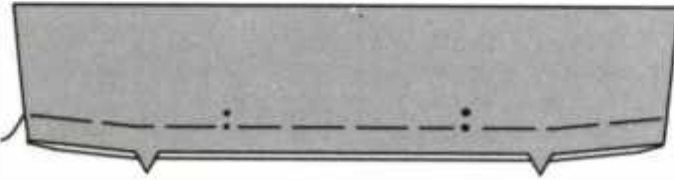
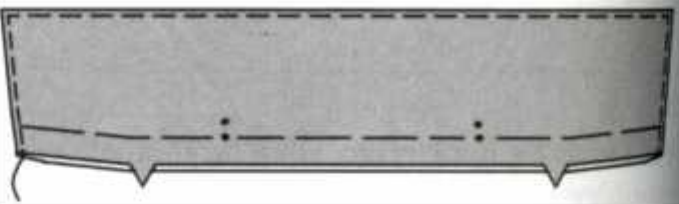
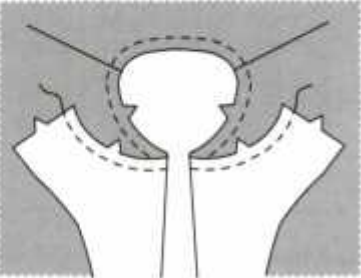
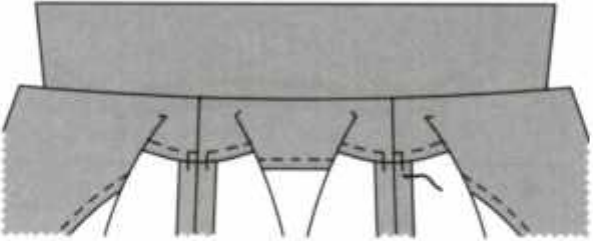
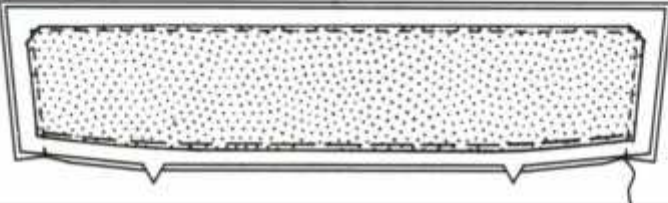

Steps 3 and 10 have been done for you.

Page 13 of 16

DO NOT WRITE ABOVE THIS LINE

	<p>Turn collar and press. Baste raw edges together at lower edge.</p>	
	<p>Top stitch the finished edge of the collar.</p>	
<p>TRIM AND CLIP SEAM</p>		<p>3</p>
	<p>Stay stitch neck edge</p>	
	<p>Turn facing to inside; press. Secure at shoulder seams.</p>	
	<p>Interface wrong side of one collar section. Stitch collar sections together, leaving notched edges open.</p>	
	<p>Stay stitch neck edge of back neck facing.</p>	

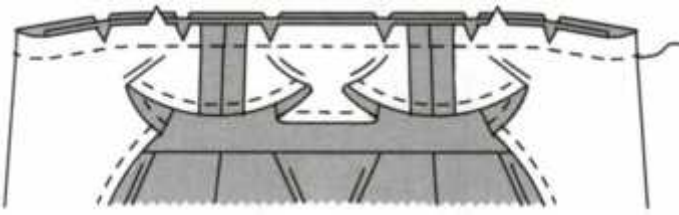
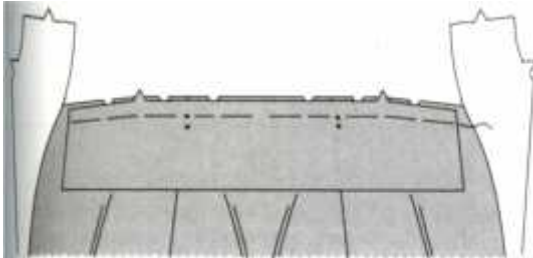
DO NOT WRITE ABOVE THIS LINE

	<p>Turn self facings to outside along fold lines. Pin facing to neck edge over collar, clipping facing where necessary. Stitch.</p>	
	<p>Pin collar to neck edge between large ●'s, interfaced side up, matching small ● ●'s to shoulder seams and clipping garment neck edge where necessary; baste.</p>	
<p>TRIM AND CLIP SEAM</p>		<p>10</p>
	<p>Stitch back neck facing to front self facings at shoulders. Finish outer edge.</p>	

(9 marks)

b) Explain the purpose of stay stitching whilst sewing.

(2 marks)

Please turn the page.

DO NOT WRITE ABOVE THIS LINE

8. The diagrams below illustrate three different tops. Each top has a different sleeve style.

i. Name each type of sleeve.

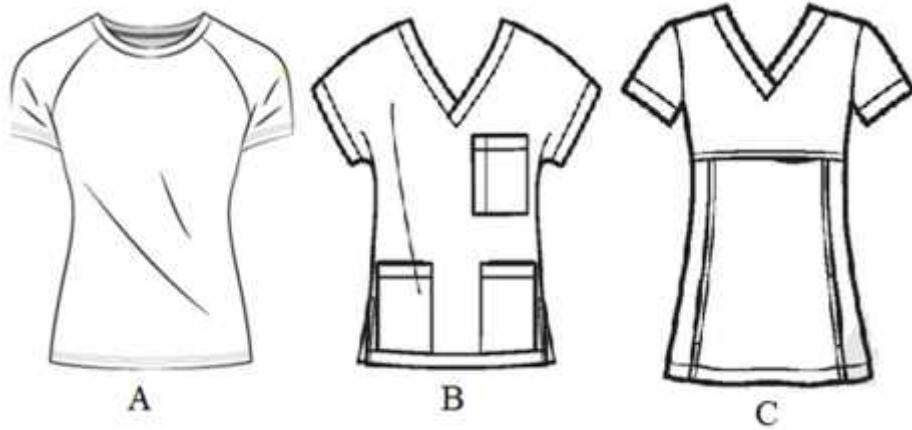

• Sleeve A: _____

• Sleeve B: _____

• Sleeve C: _____

(1, 1, 1, marks)

ii. In the space provided draw and label the sleeve pattern piece of Figure A.



(2 marks)

MATRICULATION AND SECONDARY EDUCATION CERTIFICATE EXAMINATIONS BOARD
UNIVERSITY OF MALTA, MSIDA





SECONDARY EDUCATION CERTIFICATE LEVEL
MAY 2015 SESSION

SUBJECT: **Textiles and Design**
PAPER NUMBER: **IIA**
DATE: **26th May 2015**
TIME: **9:00 a.m. to 11:00 a.m.**

Section A: Answer ALL Questions

1. There are various types of cutting tools and each one has a specific use.

a) Name the cutting tools in the pictures below and for each state its use.

 <p>Name: _____</p> <p>Use: _____</p> <p>_____</p> <p>_____</p>	 <p>Name: _____</p> <p>Use: _____</p> <p>_____</p> <p>_____</p>
 <p>Name: _____</p> <p>Use: _____</p> <p>_____</p> <p>_____</p>	 <p>Name: _____</p> <p>Use: _____</p> <p>_____</p> <p>_____</p>

(2, 2 marks)

b) List **THREE** safety rules one should follow while handling or working with cutting tools.

- i. _____
- ii. _____
- iii. _____

(3 marks)

c) Why is it important to use the cutting tools mentioned in question 1 a) on fabric only?

(1 mark)

2. Different types of sewing machines are available on the market.

a) State the name of the sewing machines which work the following stitches and give a brief description of each.

	Name of sewing machine: _____
	Brief description: _____

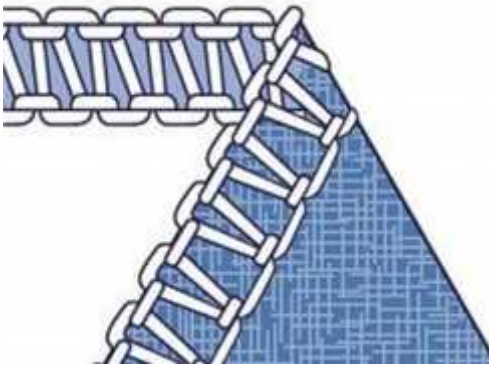
	Name of sewing machine: _____
	Brief description: _____

Name of sewing machine:												
1 	2 	3 	4 	5 	6 	7 	8 	9 	10 	11 	12 	13
14 	15 	16 	17 	18 	19 	20 	21 	22 	23 	24 	25 	

Brief description:

(3, 6 marks)

b) i) List **THREE** points one should consider before buying a sewing machine.

- _____
- _____
- _____

(3 marks)

ii) Choose **ONE** of the points considered above and give a practical example.

Point chosen: _____

Practical example: _____

(2 marks)

c) If a fault occurs in the sewing machine a few weeks after purchase, what should the consumer do?

- _____
- _____
- _____
- _____

(4 marks)

d) The following is a sewing machine needle.



List **TWO** features of the sewing machine needle.

- i. _____
- ii. _____

(2 marks)

3. There are different ways in which fibres are made into fabric.

a) Name each method of fabric construction.

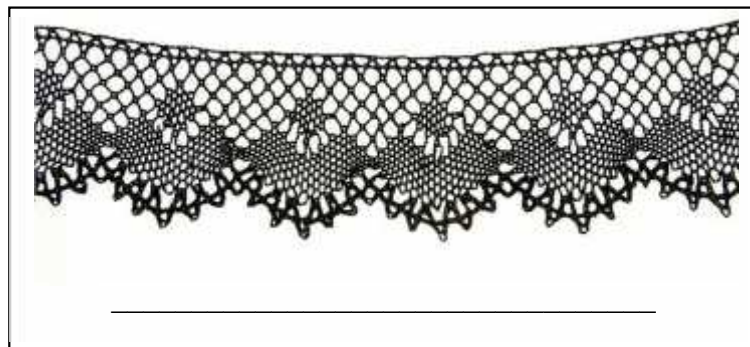
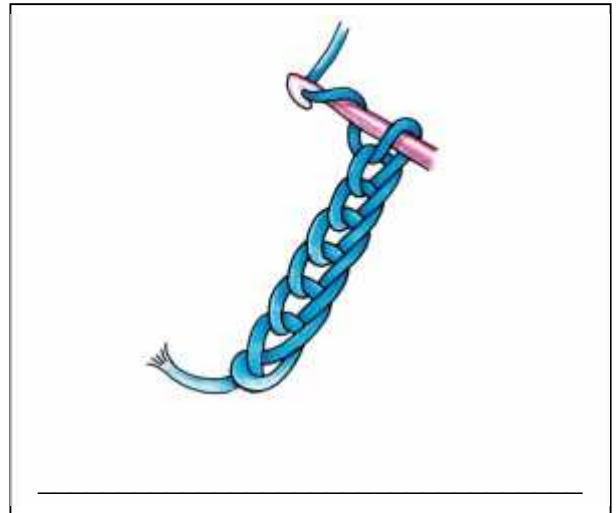
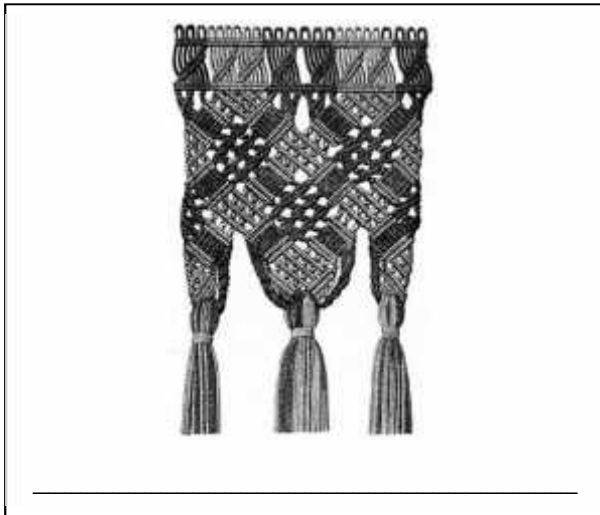

(3 marks)

b) Felting and bonding are non-woven fabrics.

i. List **TWO** examples of textile items made from:

Felting: _____, _____.

Bonding: _____, _____.

(2 marks)

- ii. Give a reason why non-woven fabrics are cheaper to produce than other fabric construction methods.

(2 marks)

4. It is important to choose environmentally friendly products and care for the environment.

- a) The EU Ecolabel below helps you identify the products which have the least impact on the environment and which are of a good quality.



- i. Name **TWO** textile items which may carry the Ecolabel symbol.

• _____ • _____

(1 mark)

- ii. Give an example how the textile item mentioned in the previous question (4a i) can be environmentally friendly.

(2 marks)

- b) Identify **TWO** ways how a woollen jumper could be reused.

i. _____

ii. _____



(2 marks)

Section B: Answer ALL Questions

5. Katia is a mother of three-year-old Samuel.

a) List **TWO** points she should keep in mind when choosing clothes for her son.

- i. _____
- ii. _____

(2 marks)

b) Katia likes to sew clothes for her son.

- i. On the template provided below, **design** a summer outfit which Katia could sew for her son. Label **FOUR** fashion features.

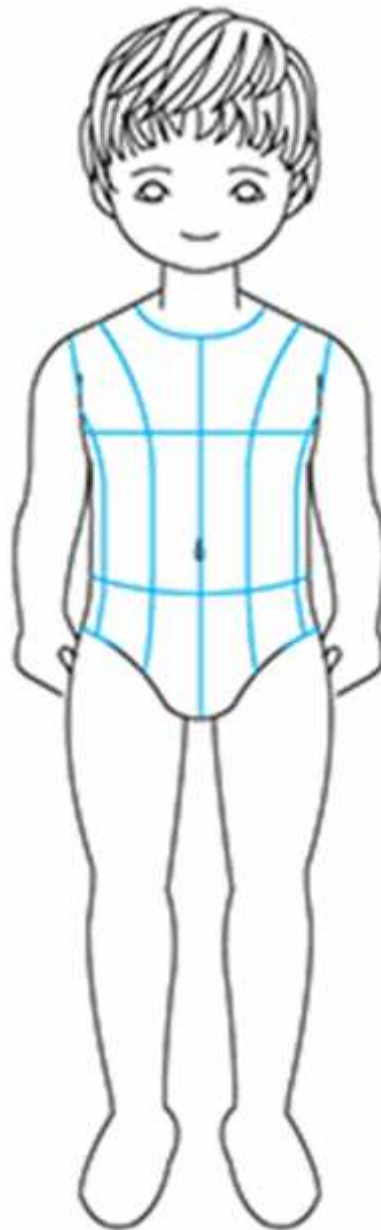

(4, 2 marks)

ii. Name a suitable fabric for the outfit drawn in question 5(b) i and give a reason for your answer.

Suitable fabric: _____

Reason: _____

(1, 2 marks)

iii. Identify the fabric colour/s you would choose for Samuel’s outfit, giving reasons for your choice.

(2 marks)

iv. Give **TWO** advantages of making the outfit rather than buying it.

- _____
 - _____
- (2 marks)

c) Sometimes Katia finds it convenient to buy clothes online. However she gets tempted to impulse buying.

i. Define impulse buying.

(1 mark)

ii. Identify **TWO OTHER** disadvantages of online shopping for clothes.

- _____
 - _____
- (2 marks)

d) List **TWO** ways how advertisements are used to encourage mothers to buy ready-made clothes for their children.

- i. _____
 - ii. _____
- (2 marks)

6. Manufactured fibres are divided into two categories: Regenerated and Synthetic.

a) Define the terms **Regenerated fibres** and **Synthetic fibres** and name **TWO** regenerated fibres and **ONE** synthetic fibre.

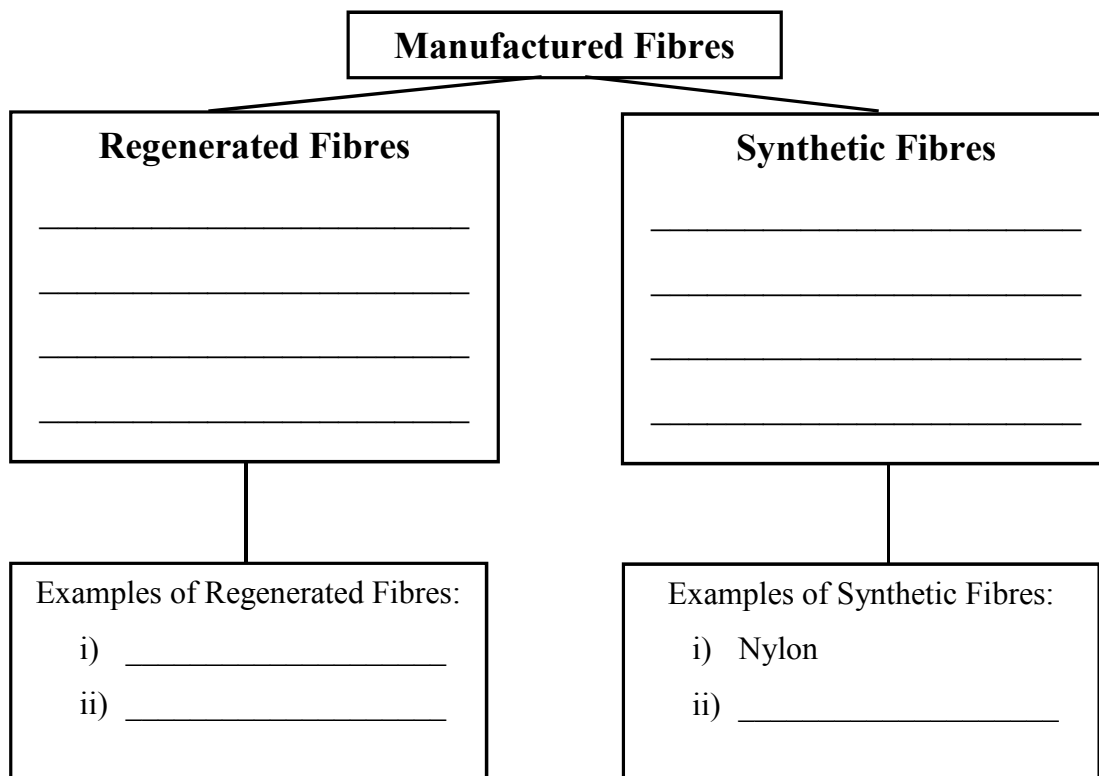

(2, 1½ marks)

b) Manufactured fibres are often blended or mixed with natural fibres.

i. Give **TWO** reasons why manufactured fibres are blended with natural fibres.

- _____
- _____

(4 marks)

ii. Explain the difference between **blends** and **mixtures**.

(2 marks)

c) Nylon is a synthetic fibre widely used in many textile items.

i. Name **TWO** textile items made from nylon and, for each, state **ONE** property which makes nylon suitable to be used for that item.

• **Textile item 1:** _____
Property: _____

• **Textile item 2:** _____
Property: _____

(1, 2 marks)

ii. Manufacturers carry out various fabric tests to ensure that the fabric (such as nylon) is fit for its purpose. Name the fabric test below and explain the method of the fabric test.

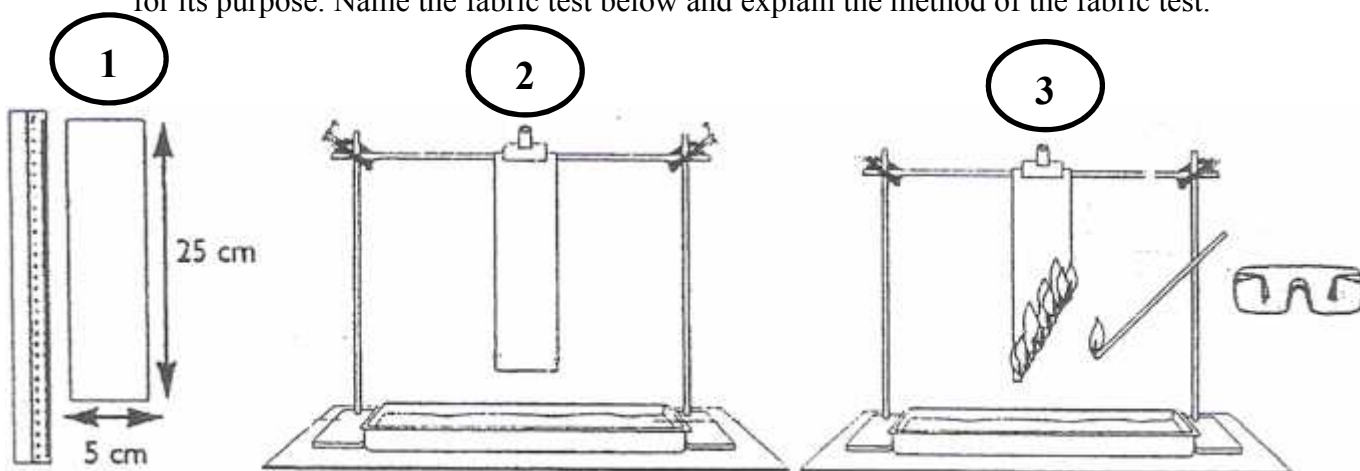

Name of fabric test: _____ (½ mark)

Method:

1 _____

2 _____

3 _____

(3 marks)

iii. Nylon is thermoplastic. Give the meaning of *thermoplastic*.

_____ (1 mark)

iv. Nylon is also electrostatically charged.

- Give the meaning of *electrostatically charged*.

_____ (1 mark)

- What can be added to the final rinse to reduce static electricity in nylon?

_____ (1 mark)

- Name the finish which manufacturers apply to nylon to reduce static electricity.

_____ (1 mark)

v. Give another **TWO** trade names for nylon.

- _____
- _____

(1 mark)

7. You have been asked to make a presentation on silk to Form 3 students.

a) In the boxes provided below describe the natural process from which silk originates.

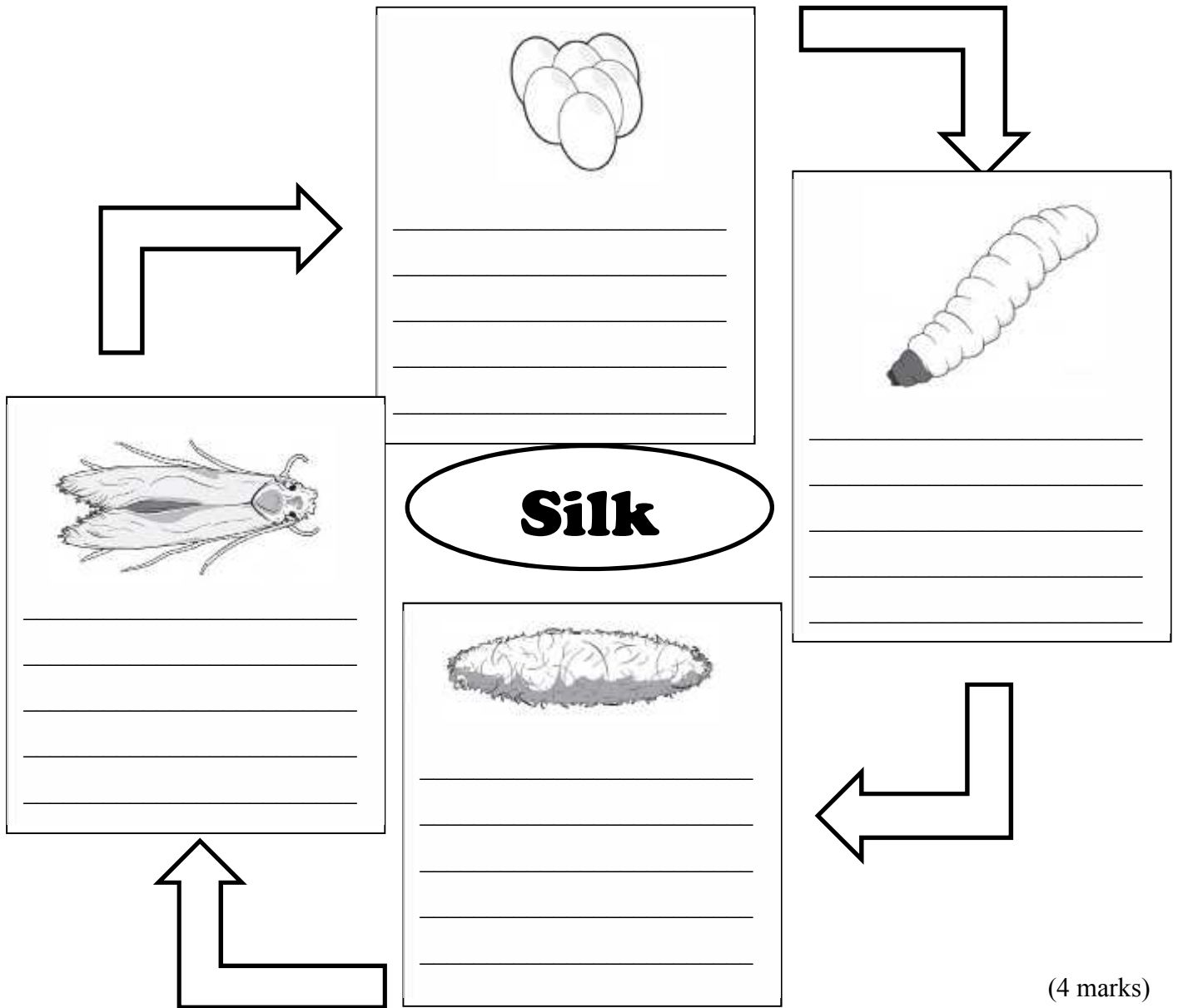

(4 marks)

b) Explain to the students what is:

- Raw silk:

- Spun silk:

(2 marks)

c) Name **ONE special** quality of silk.

_____ (1 mark)

d) Why is silk a very expensive fibre?

_____ (1 mark)

e) Silk is a very delicate fabric and should be laundered carefully. Explain how silk is:

i. Hand washed

_____ (2 marks)

ii. Ironed

_____ (2 marks)

iii. Draw the care label symbol for parts (i) and (ii).

Care label symbol for (i)	Care label symbol for (ii)

(2 marks)

f) Identify **ONE** factor which damages silk.

_____ (1 mark)

g) Silk is a slippery fabric and machining is likely to pucker. How could this be avoided?

_____ (1 mark)

h) Which machine needle should be used when sewing silk fabrics?

_____ (1 mark)

i) Name **TWO** main silk-producing countries.

i. _____ ii. _____

(2 marks)

MATRICULATION AND SECONDARY EDUCATION CERTIFICATE EXAMINATIONS BOARD
UNIVERSITY OF MALTA, MSIDA

SECONDARY EDUCATION CERTIFICATE LEVEL





MAY 2015 SESSION

SUBJECT: **Textiles and Design**
PAPER NUMBER: **IIB**
DATE: **26th May 2015**
TIME: **9:00 a.m. to 11:00 a.m.**

Section A: Answer ALL Questions

1. There are various types of cutting tools and each one is used for different tasks.

a) **Name** the cutting tools in the pictures below and **match** with its use.

Types of cutting tools	Use
<div style="border: 1px solid black; border-radius: 50%; width: 30px; height: 30px; display: flex; align-items: center; justify-content: center; margin-bottom: 5px;">1</div>  <p>Name: _____</p>	For quick cutting and trimming of thread.
<div style="border: 1px solid black; border-radius: 50%; width: 30px; height: 30px; display: flex; align-items: center; justify-content: center; margin-bottom: 5px;">2</div>  <p>Name: _____</p>	To unpick seams and open buttonholes.
<div style="border: 1px solid black; border-radius: 50%; width: 30px; height: 30px; display: flex; align-items: center; justify-content: center; margin-bottom: 5px;">3</div>  <p>Name: _____</p>	To snip corners off fabric and for close accurate cutting.
<div style="border: 1px solid black; border-radius: 50%; width: 30px; height: 30px; display: flex; align-items: center; justify-content: center; margin-bottom: 5px;">4</div>  <p>Name: _____</p>	For finishing fabric edges by producing a zigzag edge to prevent the fabric from fraying or for an attractive finish.
<div style="border: 1px solid black; border-radius: 50%; width: 30px; height: 30px; display: flex; align-items: center; justify-content: center; margin-bottom: 5px;">5</div>  <p>Name: _____</p>	For cutting out fabrics.

(2½, 2½ marks)

b) Give **THREE** safety rules one should follow while handling or working with cutting tools.

- i. _____
- ii. _____
- iii. _____

(3 marks)

c) It is important to use the cutting tools mentioned in question 1 (a) on fabric only. What would happen if they are repeatedly used on paper?

_____ (1 mark)

2. There are different types of sewing machines available in shops.

a) Name the sewing machine which works the following stitches and give its use.



Name of sewing machine: _____

Use: _____

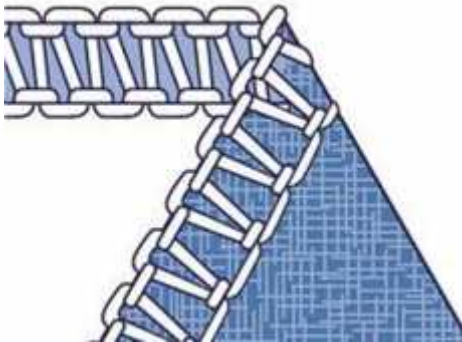

Name of sewing machine: _____

Use: _____

1	2	3	4	5	6	7	8	9	10	11	12	13
14	15	16	17	18	19	20	21	22	23	24	25	

Name of sewing machine: _____

Use: _____

(3, 6 marks)

b) One of the first things that people consider before buying a sewing machine is their budget allowance. List **TWO** other points one should consider before buying a sewing machine.

i. _____

ii. _____

(2 marks)

c) Suggest **THREE** ways how to take care of a sewing machine.

i. _____

ii. _____

iii. _____

(3 marks)

d) The structure of a sewing machine needle is different from a sewing needle.

i. Fill in the blanks with the words provided below on the structure of a sewing machine needle.

	Eye	Flat	Sizes	Fabric	
Inserted	Round	Groove	Backwards	Thread	

A sewing machine needle is _____ at the top front and _____ at the top back. This is so that it cannot be inserted _____. On the round side of the sewing machine needle is a _____. When the needle is _____ in the sewing machine, the _____ will travel down the groove and through the _____. There are various needle _____ and it should be changed according to the _____ type you are working with.

(4 ½ marks)

ii. On the sewing machine needle below label the:

Point

Eye

Groove



(1 ½ marks)

3. Fibres are made into fabric in a number of ways.

a) The following are hand techniques which produce decorative fabric from yarns. Name each method used.

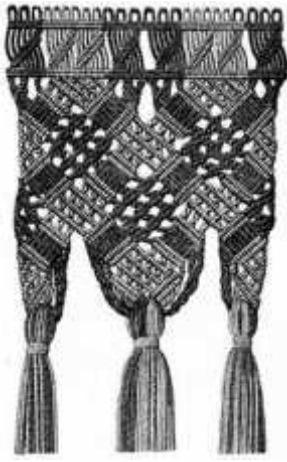

A hand technique where the yarns are knotted together producing an item with holes.



The yarn is looped with a crochet hook, producing chains which are linked together.

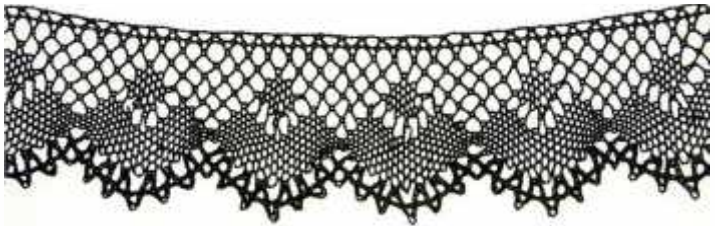





A traditional Maltese skill where bobbins are used to twist and knot yarns together, producing a delicate fabric made by hand. Machines can also be used, creating a less expensive fabric. _____

(3 marks)

b) Felting and bonding are non-woven fabrics.

Underneath each textile product, write down whether each one is made from **felting** or **bonding**.

			
<p>Soft toy</p>	<p>Hat</p>	<p>Disposable face mask</p>	<p>Hair net</p>
<p>_____</p>	<p>_____</p>	<p>_____</p>	<p>_____</p>

(2 marks)

4. It is important to care for the environment by choosing environmentally friendly products.

a) The EU Ecolabel below is found on products which are safe for the environment and are of a good quality.



i. The Ecolabel symbol accompanies this pair of slippers.



Suggest **ONE** way how this pair of slippers can be environmentally friendly.

(1 mark)

ii. Name **another** textile item which can carry the Ecolabel symbol.

(1 mark)

b) An old woollen jumper like the one shown below can be recycled.



i. Suggest **TWO** textile items which could be made from this woollen jumper.

• _____ • _____

(2 marks)

- ii. Choose **ONE** textile item suggested in the previous question 4 b) i. and sketch it in the box provided below.

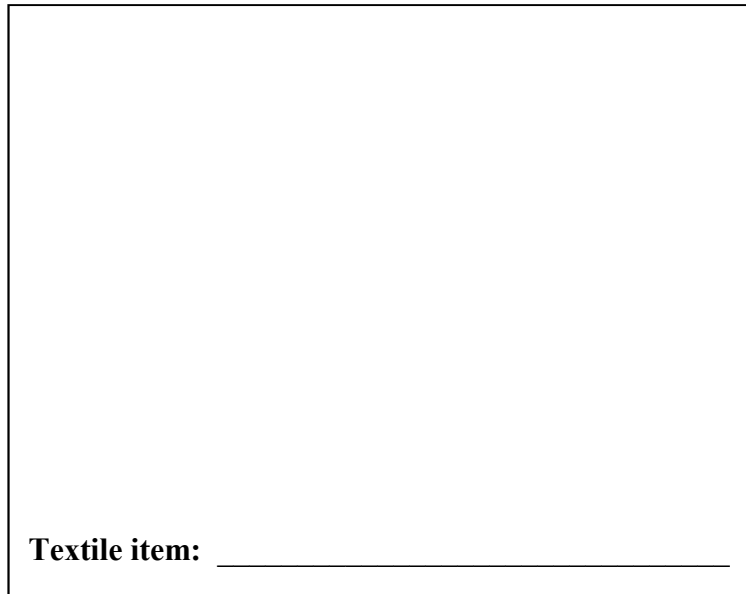

Textile item: _____

(2 marks)

Section B: Answer ALL Questions

5. Katia is the mother of three-year-old Samuel.

a) Suggest **TWO** factors she should consider when choosing clothes for her son, keeping in mind that he is very active.

i. _____

ii. _____

(2 marks)

b) Katia likes to sew clothes for her son.

i. On the template provided, below **design** a summer outfit which Katia could sew for her son. Label **ONE** fashion feature.

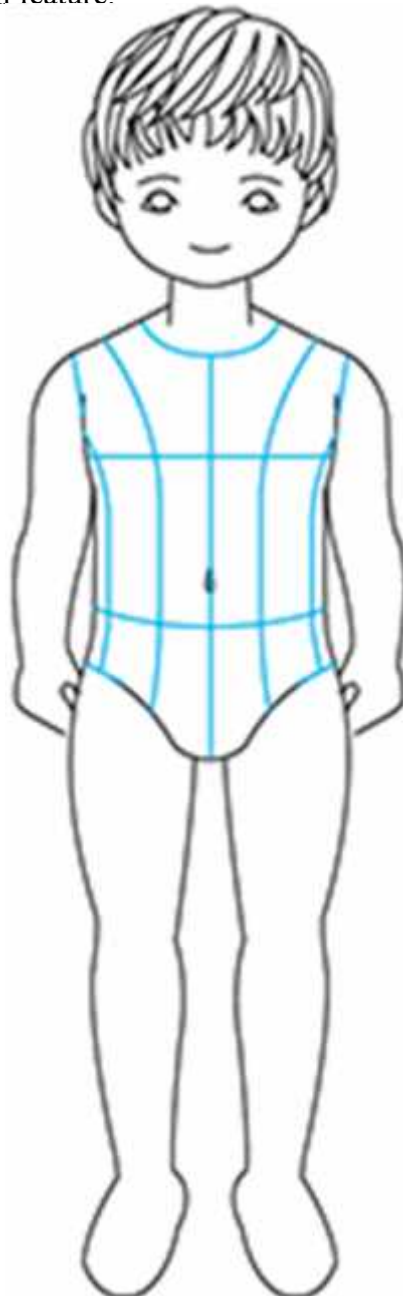

(4, 1 marks)

ii. When sewing a summer outfit for her son, she prefers to choose 100% cotton. List **TWO** advantages for choosing this fabric for the summer outfit.

- _____
- _____

(2 marks)

iii. Suggest a suitable colour / colour scheme for Samuel’s summer outfit and give **one** reason for your choice.

Suitable colour/colour scheme: _____

Reason: _____

(1, 2 marks)

iv. Give **TWO** advantages why it is a good idea for Katia to sew her son’s clothes.



- _____
- _____

(2 marks)

v. When designing Samuel’s clothes, Katia often includes features that make allowance for different purposes. Suggest **ONE** of such features.

(1 mark)

c) There are special occasions that may drive you to impulse buying when shopping for ready-made clothes.



i. Define impulse shopping.

_____ (1 mark)

ii. Why should you avoid buying clothes impulsively?

_____ (1 mark)

iii. Shopping online from the comfort of your home, instead of going out to various shops is very convenient. Unfortunately, there are some disadvantages when shopping from the internet.



Give **TWO** disadvantages that Katia should be aware of.

- _____
- _____

(2 marks)

d) The following advertisement in a shop window encourages mothers to buy ready-made clothes for their children. Name **TWO** other types of advertisements.

i. _____

ii. _____



(2 marks)

6. Manufactured fibres are divided into *Regenerated* and *Synthetic*.

a) Give the meaning of the words in italics.

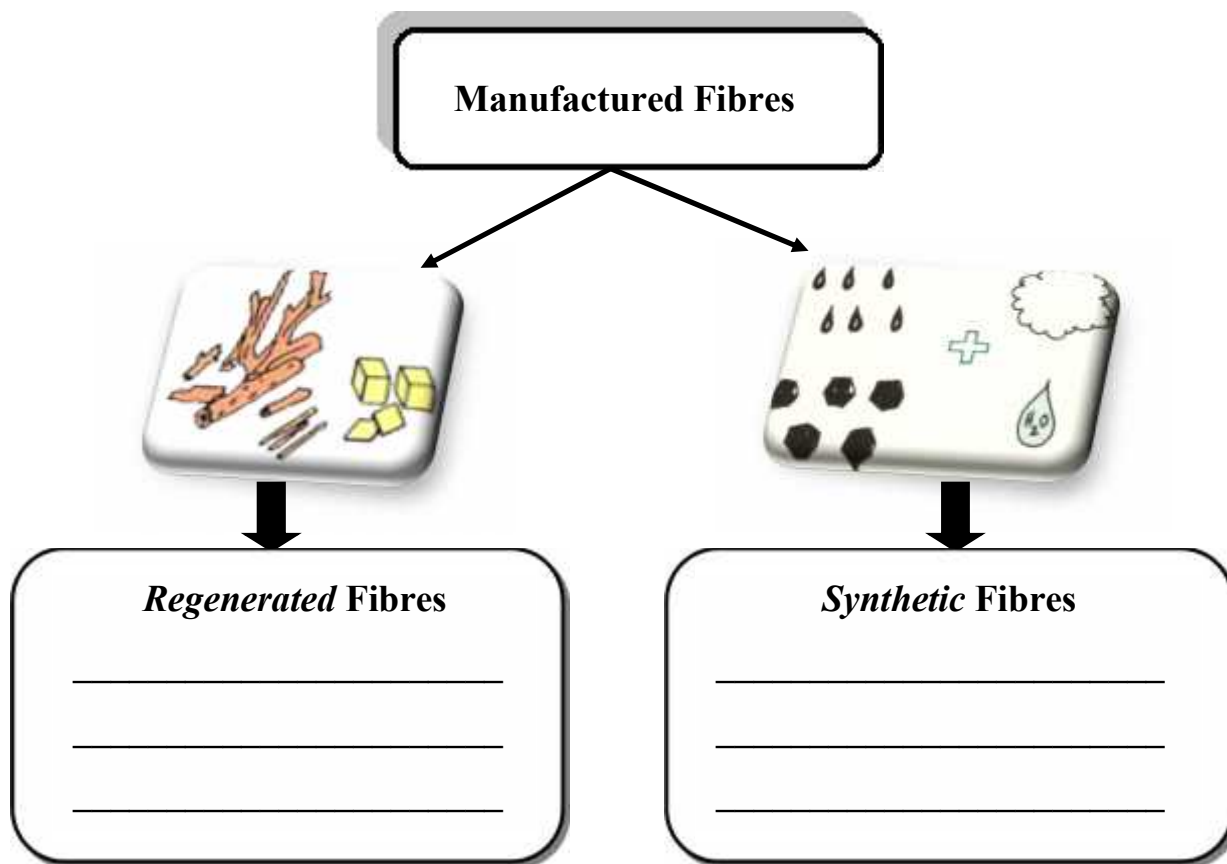

(2, 2 marks)

b) Nylon is a synthetic fibre and has been widely used in many textile items.

i. Name **TWO** textile items made from nylon. For each, give **ONE** property which makes nylon suitable to be used for that item.

• **Textile item 1:** _____
Property: _____

• **Textile item 2:** _____
Property: _____

(2, 2 marks)

ii. Give another name for nylon.

(½ mark)



c) Fill in the blanks with the following words.

bondaweb mixture blend
staple felt continuous

- Manufactured fibres are generally made using _____ filaments.
- For blending, the manufactured fibres should be cut into _____ fibres.
- A _____ is a fabric in which each yarn is made of a different fibre and then the yarns are used together to construct cloth.
- A _____ is a fabric in which different sorts of fibres are mixed together before or during the spinning process.
- _____ is used for items like soft toys and hats.
- _____ is a very lightweight fabric soaked in heat-sensitive glue, used for such things as turning up hems.

(½, ½, ½, ½, ½, ½ mark)

d) Nowadays manufactured fibres are often blended or mixed with natural fibres.

Give **ONE** reason why manufactured fibres are blended with natural fibres.

(2 marks)

e) Various fabric tests are carried out to make sure that a fabric is fit for its purpose. Name the fabric test below and explain the method used.

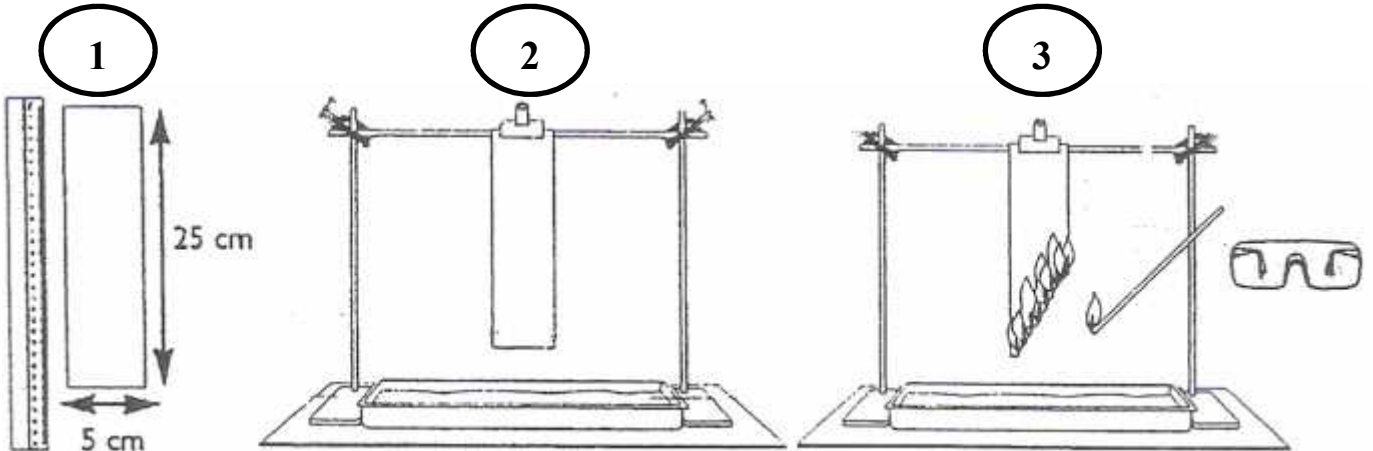

Name of fabric test: _____ (½ mark)

Method:

1 _____

2 _____

3 _____

(3 marks)

f) Thermoplastic means that a fibre can be melted and heat-set to a permanent shape. Name a fibre which has this property.

Name of fibre: _____ (1 mark)

g) Electrostatically-charged fabrics attract dirt very easily. What is added to the final rinse to reduce static electricity to this fabric?

_____ (1 mark)

h) Name the finish that is given to reduce static electricity to a fabric.

Name of finish: _____ (1 mark)



7. The diagram below shows different thread directions on a piece of woven fabric. All have been numbered and also the selvedge has been marked for you.
- a) Choose from the words given below and fill in the numbered table with the correct name. Give a brief description of each.

Bias, weft, warp, and true bias

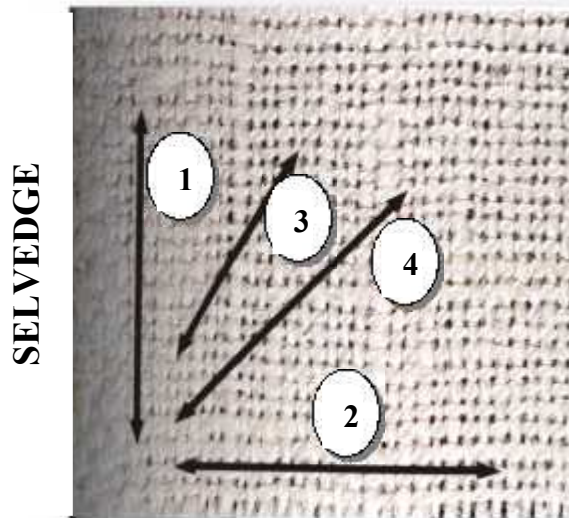

	Name of thread	Description of each thread
1		
2		
3		
4		

(1/2, 1/2, 1/2, 1/2, 4 marks)

- b) Give **ONE** example where bias cut fabric can be used.

(1 mark)

8. a) In the boxes provided below describe the natural process of the production of silk.

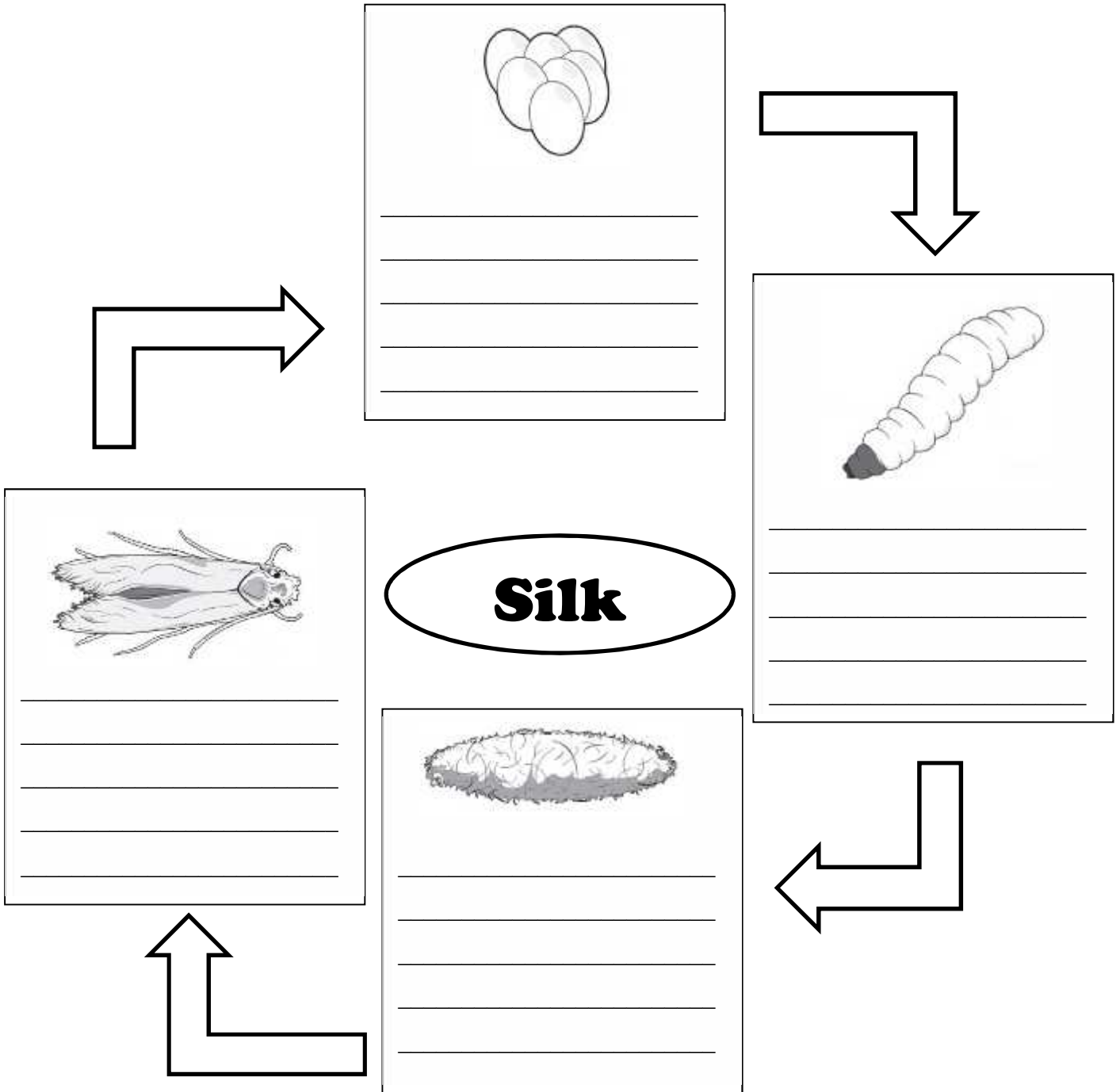

(4 marks)

b) Name **ONE special property/quality** of silk .

(1 mark)

c) Why is silk a very expensive fibre?

_____ (1 mark)

d) Silk is a very delicate fabric and should be washed carefully. Explain how silk is:

i. Hand washed;

_____ (2 marks)

ii. Ironed.

_____ (2 marks)

iii. Draw a circle around the **correct** washing and ironing symbols for silk, from the diagrams given below.

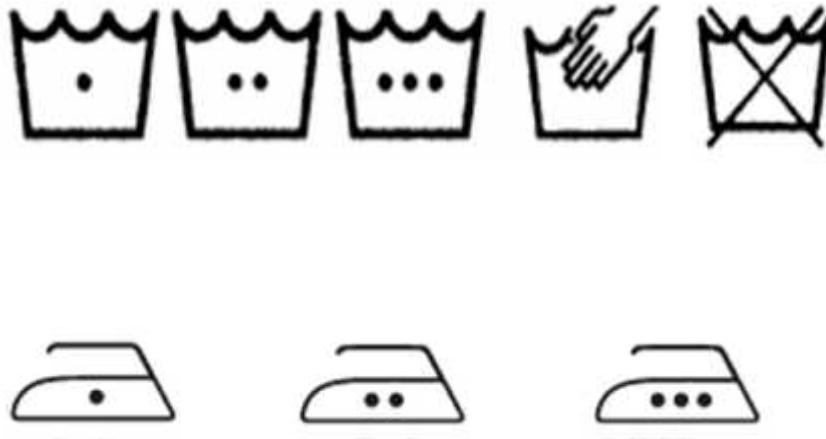

(1, 1 mark)

Blank Page